



iPack C3.3 Lithium Iron Phosphate Battery
Residential Energy Storage System
User Manual



Contents

About This Document	1
1 Important Safety Information	2
1.1 Warning Label	2
1.2 Precautions.....	2
2 Overview	4
2.1 Application Scenarios	4
2.2 Product Features	4
2.3 Appearance and Terminals	5
2.4 Technical Parameters	6
3 Battery Storage and Transportation	8
3.1 Safe Storage.....	8
3.2 Safe Transportation	8
4 Tools and Protective Equipment	9
5 Installation	10
5.1 Inspection before Installation	10
5.2 Battery Orientation.....	10
5.3 Wall-mounted installation under Parallel Mode	11
5.4 Installation of Battery Box	12
5.5 Junction Box InstallationJunction Box Installation.....	14
6 Electrical Connection	16
6.1 Power Terminals and Network Ports.....	16
6.2 Prepare Cables.....	16
6.3 Connect One Battery	18
6.4 Connect Batteries in Parallel	19
7 Operation	21
7.1 Power on Battery	21
7.2 Power off Battery	21
8 Maintenance	22
8.1 Replace Battery	22
8.2 Upgrade Firmware	22
8.3 Troubleshooting	24
9 Product Liability	25
10 Recycle	26

About This Document

Purpose



This document describes the application scenarios, installation, electrical connection, commissioning and troubleshooting of iPack C3.3, a 3.3kWh standalone Energy Storage Battery (hereinafter simply put as battery). Before installing and operating battery, please ensure that you are familiar with product features, functions, and safety precautions as provided in this document.

Target Audience

Installer, operator, commissioning personnel, maintenance personnel of the RESS product

Symbols and Conventions

Warning and caution messages are listed in the document to remind users, installers and maintainer of safe operation.

Symbol	Description
 WARNING	Indicates a potentially hazardous situation, if not avoided, could result in serious injury or death.
 CAUTION	Indicates a potentially hazardous situation, if not avoided, may result in minor or moderate injury

1 Important Safety Information

1.1 Warning Label



Do not dispose battery in household trash.



Battery is heavy enough to cause severe injury.



Recyclable.



Keep battery away from children.



Certification in European Union area.



Do not reverse polarities.



Risk of electric shock.



Do not expose battery to flame.



Explosive gas.



Operate as specified by the manual.





Battery may leak corrosive electrolyte.



Read the manual before operating.

Nameplate

Warning Label

 Lithium Ion Battery IFpP16/122/360/[1P16S]M/-10+50/90	
Model	iPack C3.3
Nominal Voltage	51.2V
Total/Rated Capacity	64Ah/58.6Ah
Total/Rated Energy	3276Wh/3000Wh
Ingress Protection	IP20
Operating Ambient Temperature	-10°C~50°C
Max Short Current and Duration	1700A, 2ms
Shanghai Dowell Technology Co.,Ltd. Web: http://www.dowellelectronic.com Email: sales@dowellelectronic.com	
 Made in China	



WARNING AVERTISSEMENT

- Do not disassemble or alter the battery in any way.
Ne démontez ni modifiez la batterie en aucune façon.
- Do not use the battery for purposes not described in its documentation.
N'utilisez pas la batterie à des fins non décrites dans sa documentation.
- Do not drop, strike, puncture, or step on the battery.
Ne laissez pas tomber, ne heurtez pas, ne percez pas et ne marchez pas sur la batterie.
- In case of electrolyte leakage, keep leaked electrolyte away from contact with eyes or skin, immediately clean with water and seek help from a doctor.
En cas de fuite d'électrolyte, gardez l'électrolyte qui fuit loin du contact avec les yeux ou la peau, nettoyez immédiatement avec de l'eau et demander de l'aide à un médecin.
- Do not put the battery into a fire. Do not use it or leave it in a place near fire, heaters, or high temperature sources.
Ne mettez pas la batterie au feu. Ne l'utilisez pas et ne le laissez pas dans un endroit près de feu, de radiateurs ou de sources de températures élevées.
- Do not submerge the battery in water, or expose it to moisture.
Ne plongez pas la batterie dans l'eau et ne l'exposez pas à l'humidité.
- Do not allow the terminals to contact exposed wire or metal.
Ne laissez pas les bornes entrer en contact avec du fil ou du métal exposé.
- The battery is heavy and can cause injury if not handled safely.
La batterie est lourde et peut provoquer des blessures si elle n'est pas manipulée en toute sécurité.
- Keep out of reach of children or animals. Tenir hors de portée des enfants ou des animaux.



1.2 Precautions

Risks of electrolyte leakage

- Do not subject battery to strong impact.
- Do not crush or puncture battery.
- Prevent battery from falling. In case of fall, turn off the battery immediately and stop using it.
- Do not open or mutilate batteries. Released electrolyte is harmful to the skin and eyes.

Risks of fire

- Do not expose battery to direct sunlight.
- Avoid contact with conductive objects such as wires.
- Keep battery away from fire source, inflammable, explosive and chemical materials.
- Do not dispose of batteries in a fire. The batteries may explode.

Risks of electric shock

- Do not touch battery with wet hands.
- Keep battery away from children and animals.
- A battery can present a risk of electric shock and burns by high short-circuited current.
- Battery installation and wire connection must be operated by professionals.

Risks of damage

- Keep a distance to water source.
- Do not subject battery to high voltage.
- Place battery on a flat surface. Do not place any foreign object on top of battery nor step on battery.
- Battery-connected PCS should have reinforced insulation.

Table 1-1 Responses to Emergencies

Event	Description and recommended actions
Leakage	Inhalation: leave the contaminated area right now. <ul style="list-style-type: none">• Swallow: induce vomiting.• Contact with eyes: flush eyes with flowing water for 15 minutes.• Contact with skin: wash thoroughly with soap and water.• Immediately seek for medical intervention after taking emergency measures.
Fire	Battery may catch fire when heated above 150°C. Please implement the following actions: <ul style="list-style-type: none">• Extinguish fire before the battery catches fire. ABC or carbon dioxide extinguisher is recommended.• If the fire is too strong to put out, move battery to a safe place before it catches fire.• If battery is on fire, evacuate people first before seeking help from professional fire protection personnel.• If battery catches fire during charging, turn off the breaker between battery and PCS when safety can be guaranteed.
Wet battery	If battery became wet or has been submerged in water, do not access it. Immediately contact your distributor for technical assistance.
Damage	Damaged battery is dangerous and must be handled with utmost care. They are not usable for use and could pose a safety threat to people or property. If battery is suspected to be damaged, stop any operation and return it to distributor.

2 Overview

iPack C3.3 is a 3.3 kWh standalone LiFePO4 battery pack. It has a 48V battery module as the main power supply unit composed of 64 Ah cells in one parallel and 16 serial connect (1P16S). Battery coordinates with PV, power conversion system (PCS), Grid, DC Breaker and loads in the residential energy storage system.

2.1 Application Scenarios

The typical application scenarios are as shown below.

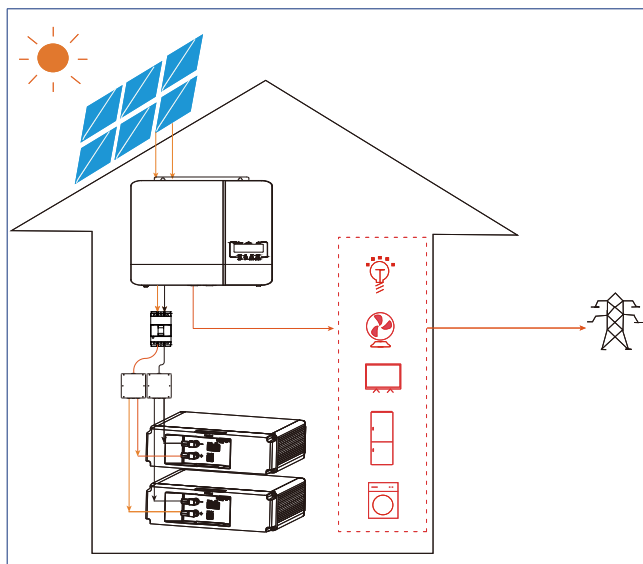

The energy produced by PV is optimized to supply loads. The excess energy is used to charge battery, then export to grid.

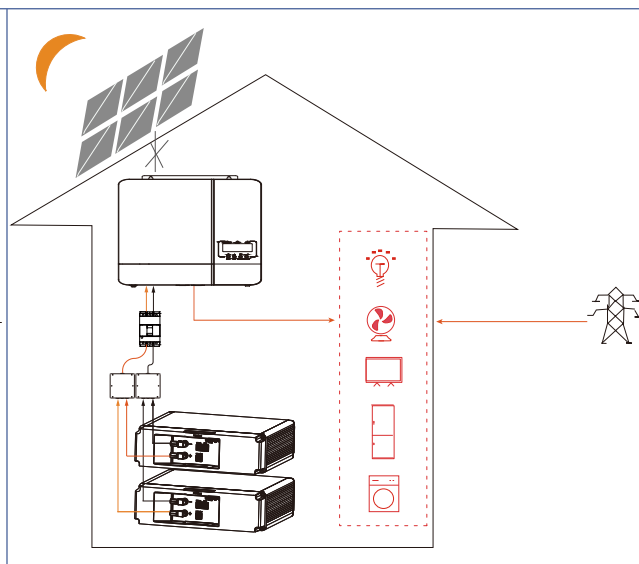

Battery powers loads at nighttime when there is no PV. If battery energy is insufficient, it can supply loads together with grid.

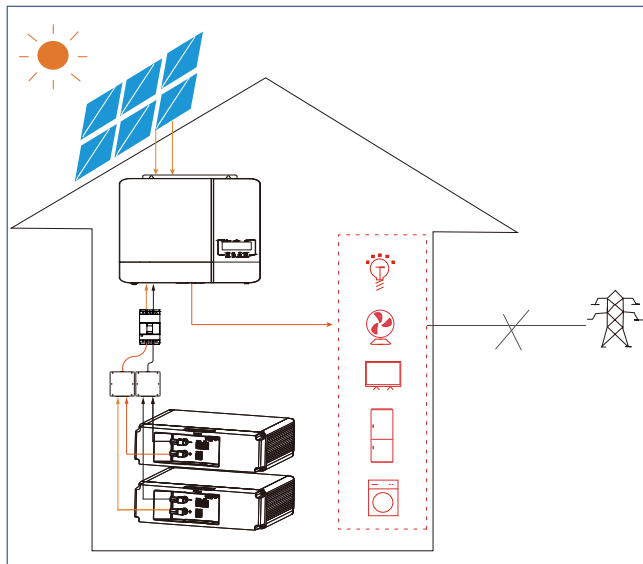

When grid falls, battery and PV can power loads.

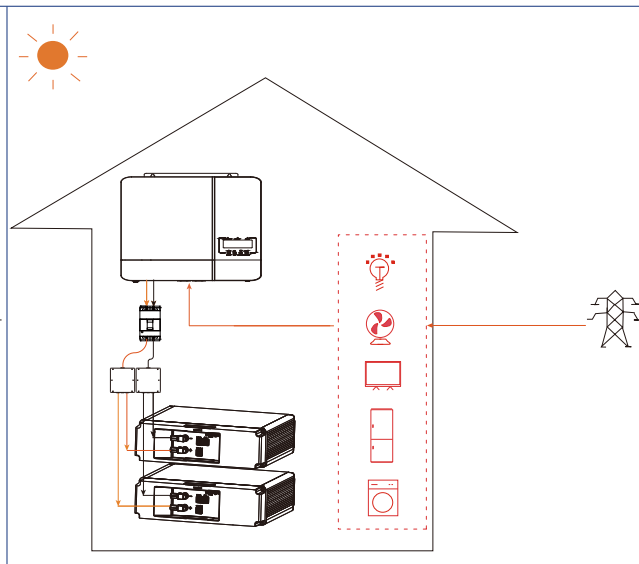

Battery can be charged by grid. Users are suggested to store energy from grid to battery when electricity price is relatively lower.

2.2 Product Features

Compared with normal batteries, the battery is characterized with better charging and discharging performance, longer cycle life and less self-discharging loss. The build-in BMS can monitor battery operation status and alarm timely to avoid operation out of limit. A maximum of 8 batteries can be parallel-connected to expand energy and power of energy storage system. Battery realizes communication with PCS via CAN network port.

- Monitoring:

Detect the voltage and temperature of cell, the voltage and current of battery.

- SOC estimate:

Indicate the precise volume of remaining electricity.

- Alarm:

Alarm when overvoltage, under voltage, overcurrent, over temperature or under temperature occurs.

- Protection:

Protect against over voltage, under voltage, over current, over temperature, under temperature, cell fault and hardware failure.

- Report:

Report alarm messages and operation data to PCS via CAN network ports.

- Parallel connection:

Support a maximum of 8 batteries in parallel connection.

- Power-off triggered by fault:

Battery powers off if level three under voltage, 0V cell or parallel connection failure happens.

- Forced power-off:

When battery does not connect to mains supply, hold POWER button for two seconds and battery powers off.

- Activation:

Input 33V~60V via P+/P- terminals, battery will be activated from off mode to standby status.

2.3 Appearance and Terminals

The battery is an energy storage unit composed of cells, mechanical parts, battery management system (BMS) as well as power and signal terminals.

Table 2-1 Mechanical features

Parameter	Value
Dimension	W445*D131*H399.6 mm
Weight	Around 30kg
Installation	Rack-mounted installation or Wall-mounted bracket installation

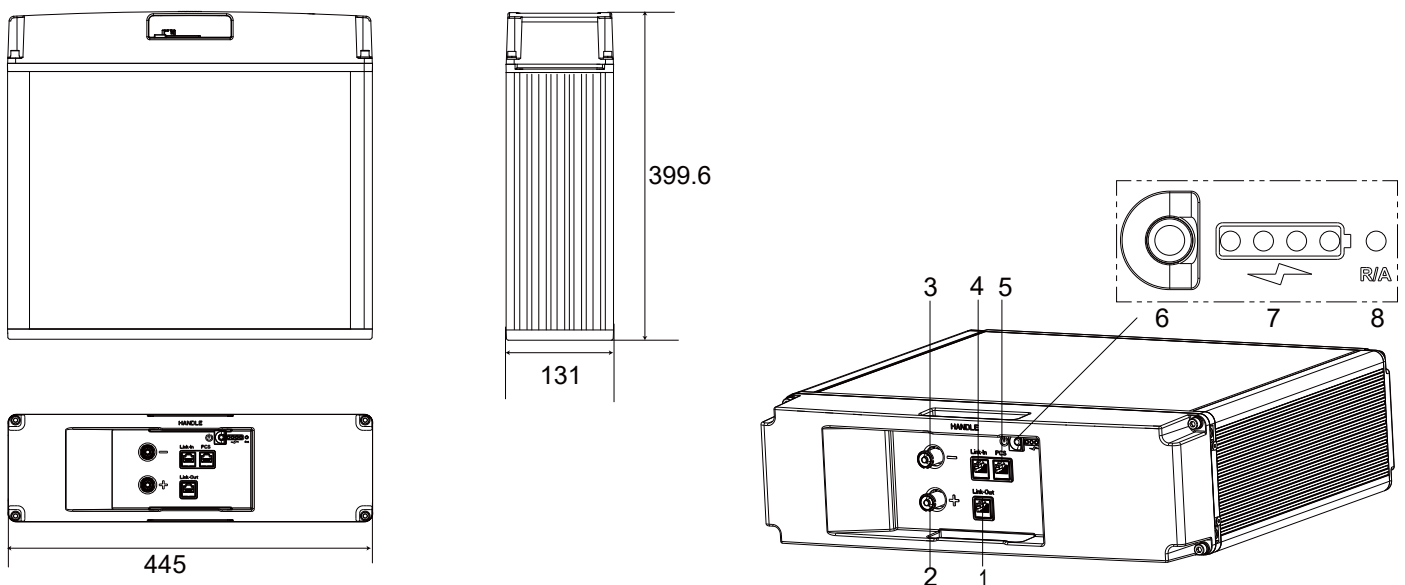



Table 2-2 Ports and terminals

No.	Label	Name
1	Link-Out	Output network port for parallel connection
2	+	Positive power terminal
3	-	Negative power terminal
4	Link-In	Input network port for parallel connection
5	PCS	Network port for communication with PCS
6	POWER	POWER button
7		SOC indicator
8	R/A	Running/Alarm indicator

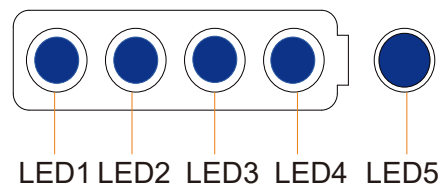

Table 2-3 LED indicators

Status	SOC Indication	LED1	LED2	LED3	LED4	LED5
Charging	0%-25.0% SOC	■				●
	25.1%-50.0% SOC	■	■			●
	50.1%-75.0% SOC	■	■	■		●
	75.1%-99.9% SOC	■	■	■	■	●
	100% SOC	●	●	●	●	●
Discharging & Standby	100%-75.1%	●	●	●	●	●
	75.0%-50.1%	●	●	●		●
	50.0%-25.1%	●	●			●
	25.0%-0%	●				●

★ : Blue LED Blink ● : Blue LED On ■ : Blue LED flash display

2.4 Technical Parameters

No.	Items	Specifications
1	Nominal Voltage (V)	51.2V
2	Total Capacity/Energy	64Ah/3.3kWh
3	Usable/Rated Capacity/Energy	58.6Ah/3.0kWh
4	Operating Voltage	44.8 ~ 57.6V
5	Max. Charging Current	-10°C ≤ T < 0°C: 10 A 0°C ≤ T < 5°C: 16 A 5°C ≤ T < 15°C: 32 A 15°C ≤ T < 45°C: 62.4 A 45°C ≤ T < 50°C: 32 A 50°C ≤ T < 55°C: 16 A

5	Max. Discharging Current	-10°C ≤ T < 0°C: 10 A 0°C ≤ T < 45°C: 62.4 A 45°C ≤ T < 50°C: 41.6 A 50°C ≤ T < 55°C: 16 A
6	Max. Discharging Power	3kW
7	Peak Discharging Power	4.14kW/60s
8	Max Charging Power	3kW
9	Peak Charging Power	4.14kW/60s
10	IP Protection	IP20
11	Operating Temperature	-10°C~+50°C
12	Recommended Operating Temperature	+15°C~+30°C
13	Storage Temperature	Temperature: -20°C ~ + 45°C, within 6 months Temperature: -30°C ~ -20°C, 45°C~ 60°C, within 7 days (for shipping state) Humidity: 5%-95%RH Within 6 month after each charge
14	RTE	94%, 0.2C charge/discharge 25°C
15	DOD	95%
16	Design life	15 years, 60%SOH
17	Cooling	Natural cooling
18	Operation altitude	≤2000m
19	Parallel Connection	Max. 8 packs
20	Communication Port	CAN
21	Safety Certification	IEC62619, CE
22	Transportation Certification	UN38.3+PI965 (Sea)
23	Environmental Certification	RoHS, REACH

3 Battery Storage and Transportation

3.1 Safe Storage

Battery storage life

Life	Temperature	Humidity
7 days	-30°C to -20°C or 45°C to 60°C	5%RH-95%RH
180 days	-20°C to 45°C	5%RH-95%RH

If the battery is not used for more than 1 week, you need to store it in accordance with the requirement for storage conditions.

- Place battery according to signs on packing box and do not put battery upside down or sidelong.
- Store batteries in a place free from direct sunlight and rain.
- Keep batteries at least two meters away from a heat source (such as a radiator).
- Avoid contacting with corrosive and organic substances (including gas exposure).
- Batteries with deficiencies should be separated from normal batteries by setting wall between or placing in difference fire protection zones.
- Keep the storage area dry, clean and well ventilated.

In case of storage over 6 months, batteries should be recharged in the following steps:

1. Identify batteries that need recharging;
2. Ensure batteries in power-off mode. Refer to Quick Guidance to complete the installation and wire connection;
3. Set "CV=56.8V, CC=16A (5°C-45°C)";
4. Recharge until LED2 flicks.

3.2 Safe Transportation

Battery has cleared UN38.3 (Section 38.3 of the Seventh Revised Edition of the Recommendations on the Transport of Dangerous Goods: Manual of Tests and Criteria) and SN/T 0370.2-2009 (Part 2: Performance Test of the Rules for the Inspection of packaging for Exporting Dangerous Goods). The battery is classified as class 9 dangerous goods, and is subject to land and water transportation. It is mandatory to report to the airline company and obtain approval before air transport.

- Before transportation, press POWER button for two seconds and five LED lights flicker for three times to power off battery.
- During transportation, put battery flat, do not have battery stand on or lean against the floor to avoid possible crash.
- Maintain temperature between -20°C to 45°C during the transportation.
- Prohibit mixing up with explosive, inflammable or toxic objects.
- Use van-type vehicle including container and metallic van-type vehicle. Platform vehicle and convertible are prohibited.
- Do not pile up foreign objects on the top of battery.
- At most four batteries in package can be piled up.
- Maintain original packaging and keep labels complete and recognizable.
- Prevent from direct sun exposure, rain, condensation and mechanical damages.

4 Tools and Protective Equipment

Before installing, operating, and maintaining the battery, you need to prepare tools and protection equipment to ensure safety.

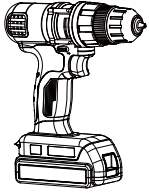

Drill

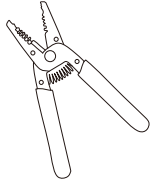

Wire stripper

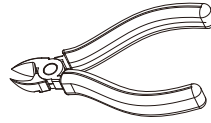

Wire cutter

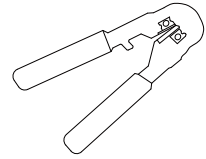

Wire crimper

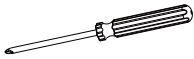

Screwdriver

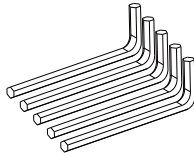

Hex key



Tape measure

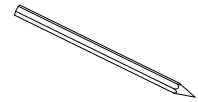

Mark pencil

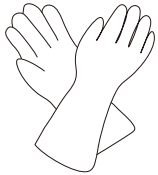

Insulated gloves

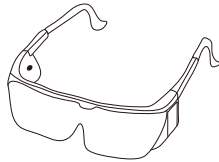

Safety goggle



Safety shoes

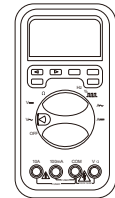

Multi-meter

To prevent injury, always wear acid-resistant clothing, PVC gloves, goggles and rubber boots during installation, operation, and maintenance.

5 Installation

It is recommended to install the battery into a cabinet and place it indoor. If you install it outdoor, select a cabinet with a sufficient IP rating. Build sunshade & rain shelter to avoid direct exposure to sunlight and rain for outdoor application.

5.1 Inspection before Installation

Before installation, check carefully for any damages on the package and the products and inspect if all accessories in the list are included. If any part is missing or damaged, please contact your distributor.



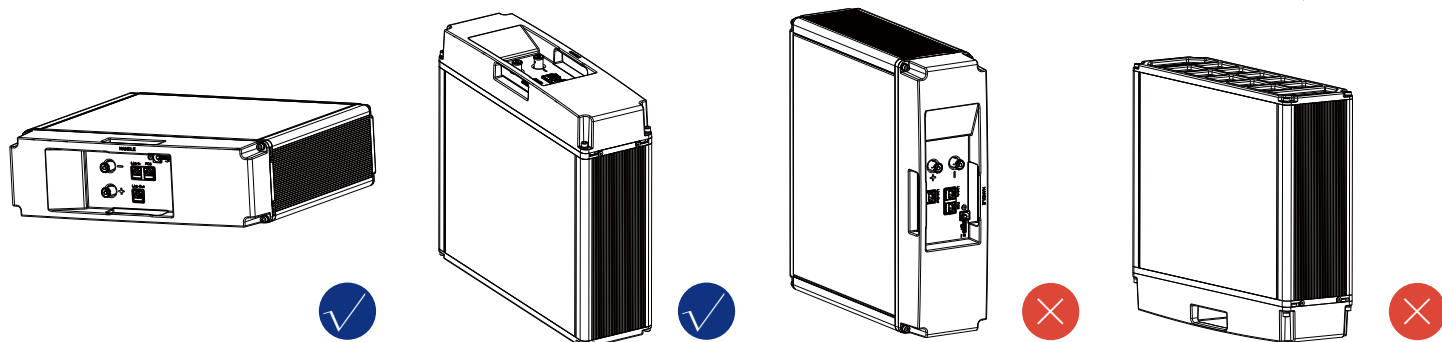

Item NO.	Part Name	Quantity	Item NO.	Part Name	Quantity
1	Standalone Battery	1pcs	5	User Manual	1pcs
2	Bracket	2pcs	6	Quick Guidance	1pcs
3	Screw	4pcs	7	Warranty Card	1pcs
4	Crystal plug	2pcs	8	Accessory List	1pcs

5.2 Battery Orientation

The battery can be installed in any direction except upside down and at most 8 pcs of batteries can be connected in parallel (up to 8p).

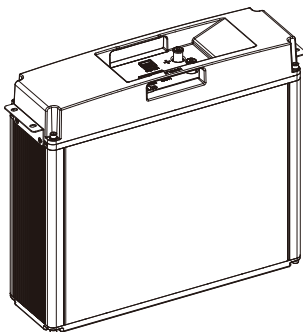

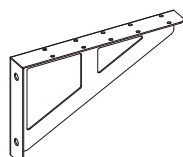
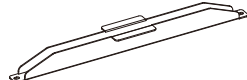
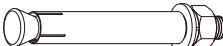
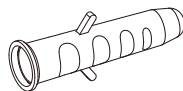
5.3 Wall-mounted installation under Parallel Mode

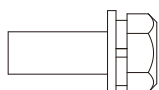
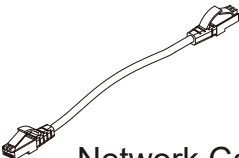
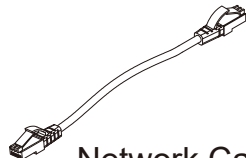
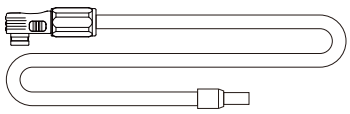
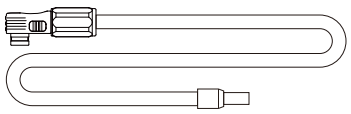
List	
No.1	Battery
	
No.2	No.3
 <p style="text-align: center;">Junction Box</p>	 <p style="text-align: center;">Bracket</p>
No.4	No.5
 <p style="text-align: center;">Connecting plate</p>	 <p style="text-align: center;">Expansion Bolt M10*80</p>
No.6	No.7
 <p style="text-align: center;">Expansion Tube 6*30</p>	 <p style="text-align: center;">Screw M4*30</p>
No.8	No.9
 <p style="text-align: center;">M5*16 Bolts</p>	 <p style="text-align: center;">Network Cable A</p>
No.10	No.11
 <p style="text-align: center;">Network Cable B</p>	 <p style="text-align: center;">Positive Cable</p>
No.12	
 <p style="text-align: center;">Negative Cable</p>	

iPack C3.3	1	2	3	4	5	6	7	8
No.1	1	2	3	4	5	6	7	8
No.2	1	1	1	1	1	1	1	1
No.3	2	2	3	3	4	4	5	5
No.4	1	1	2	2	3	3	4	4
No.5	4	4	6	6	8	8	10	10
No.6	8	8	8	8	8	8	8	8
No.7	8	8	8	8	8	8	8	8
No.8	4	10	14	20	24	30	34	40
No.9	1	1	1	1	1	1	1	1
No.10	0	1	2	3	4	5	6	7
No.11	1	2	3	4	5	6	7	8
No.12	1	2	3	4	5	6	7	8

5.4 Installation of Battery Box

Punch hole on the wall

1. Choose a suitable position to place battery on the cement wall or brick wall.

2. Confirm the quantity and position of fixing holes, 2 holes per column, the hole spacing is 120mm; column spacing is 484mm, the hole below is at least 350mm from the ground.

1-2 batteries: 2 column holes;

2-4 batteries: 3 column holes;

5-6 batteries: 4 column holes;

7-8 batteries: 5 column holes;

3. This quick guidance is based on 6 batteries.

4. Positioning the hole on the wall, punch hole with impact drill, the diameter is 12mm, depth is 80-85mm. Press the expansion bolt into the punched hole.

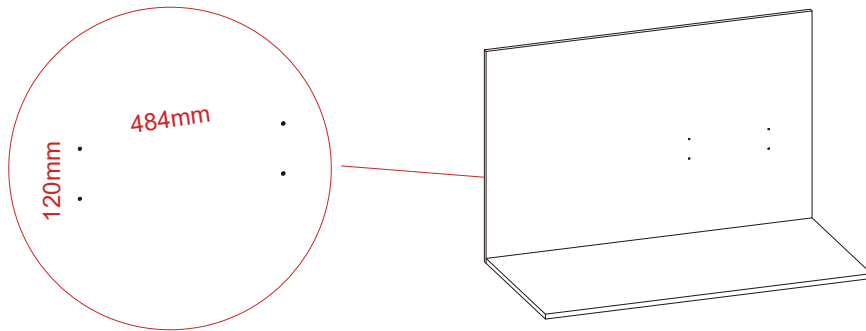

Fix the battery bracket to the wall.

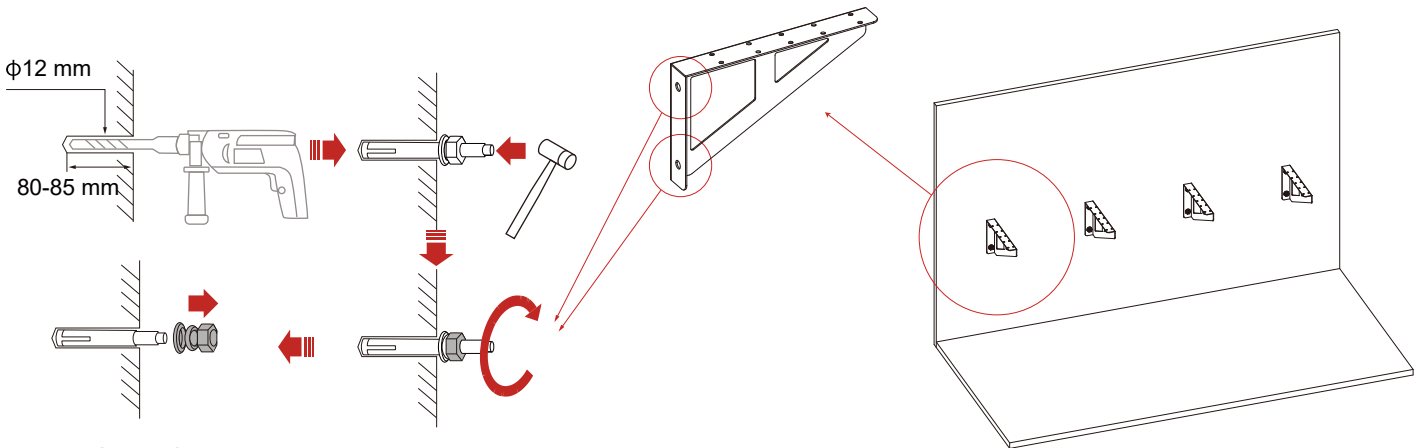

Prepare batteries.

Take the battery out of its package and fix two rack-mounted brackets to battery with screws.

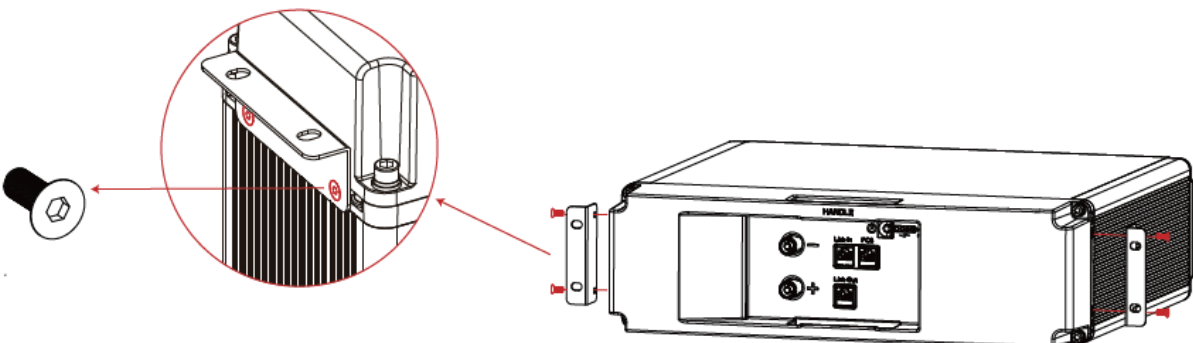

Fix the inner battery

Place the inner battery on the battery holder and lock it with M5*16 bolts, torque is 4NM.

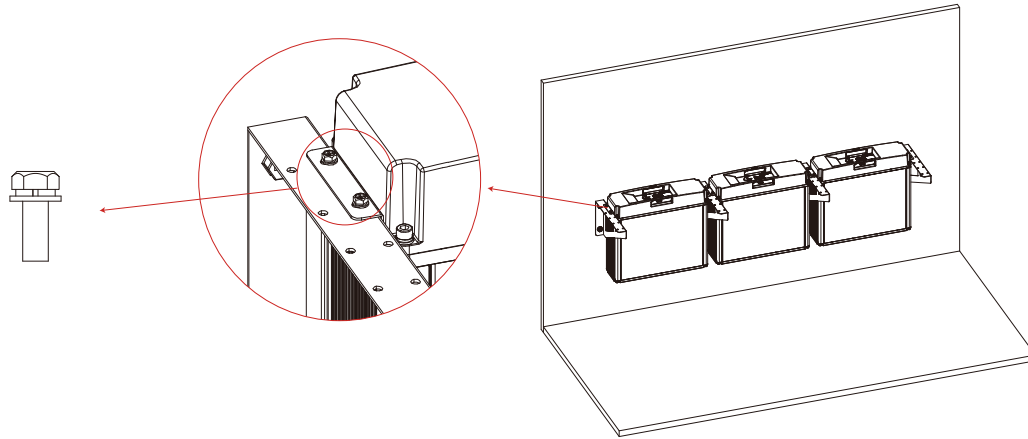

Fixing bracket connecting plate

Place connecting plate on the bracket and lock it with M5*16 bolts, torque is 4NM.

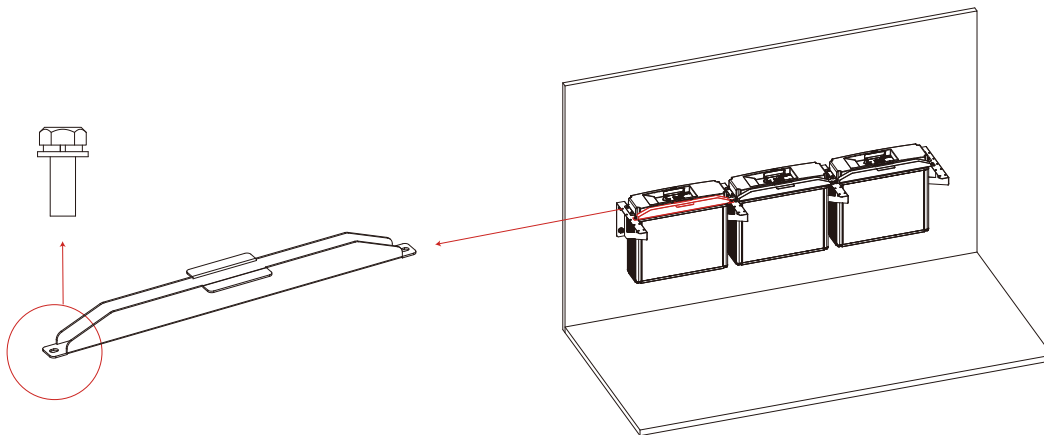

Fix the outside battery

Place the outside battery on the battery holder and lock it with M5*16 bolts, torque is 4NM.

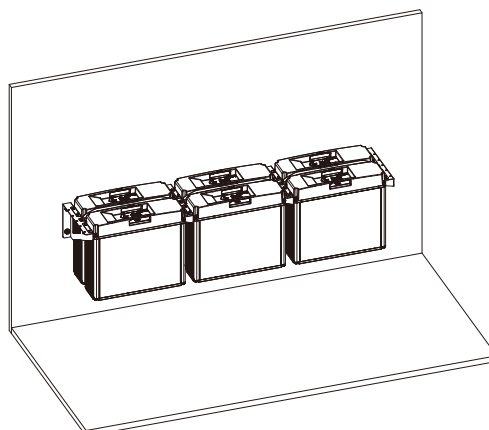

Junction Box Installation

Punch 8 holes with a diameter of 6mm on the wall where fixed the junction box, the horizontal hole spacing is 126mm, the vertical hole spacing is 146mm, the depth is 50-55mm, and place the plastic expansion tube 6*30 in the hole.

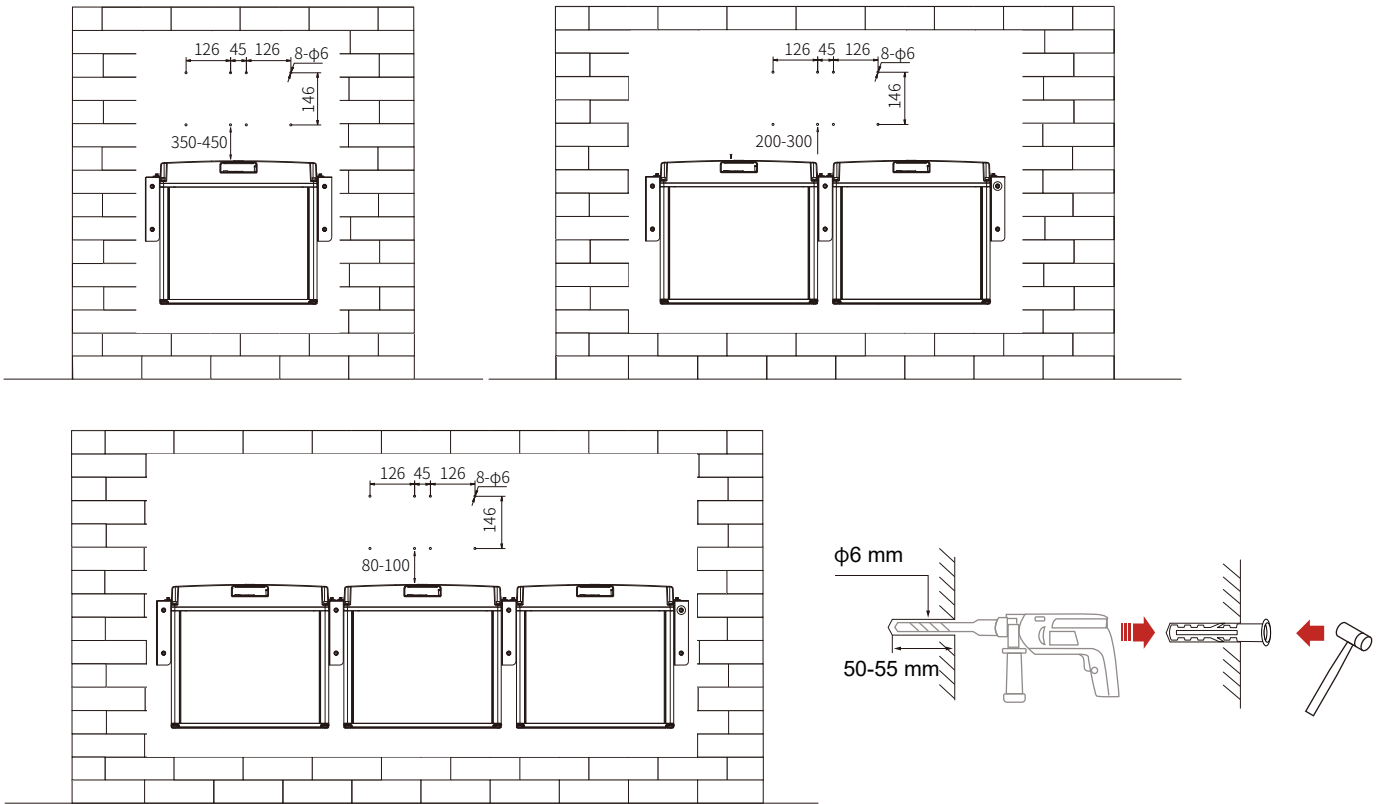

Use M4*30 screws to fix the Junction box to the wall through the 8 fixing holes at the bottom of the Junction box.

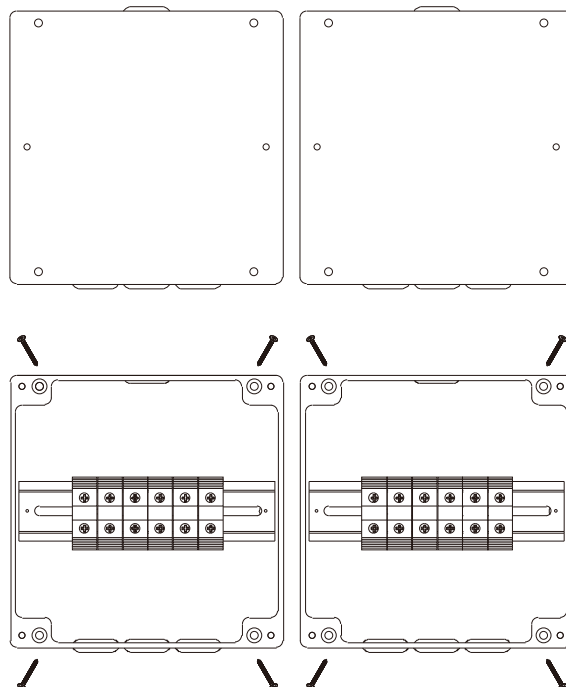

Connect the positive / negative inverter cable to the left / right hole of the MCB respectively.

Two Batteries

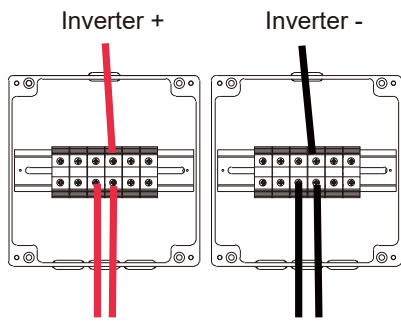

Four Batteries

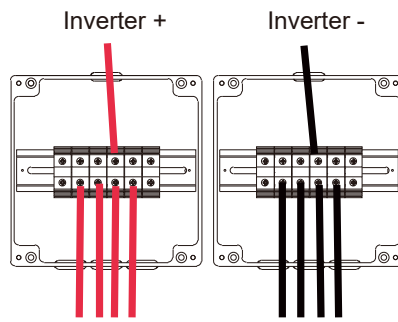

Six Batteries

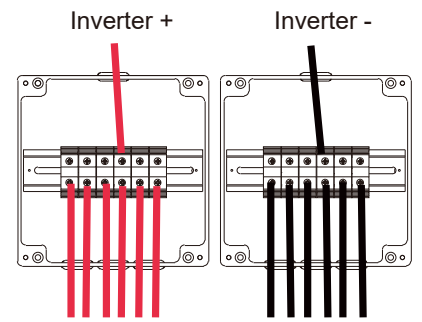

Fix the upper cover of the Junction box to the bottom with self-tapping nails.

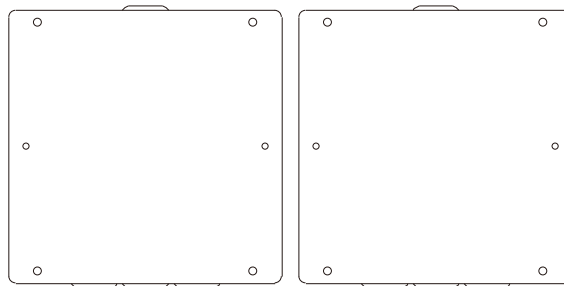

6 Electrical Connection

iPack C3.3 can work in single mode and parallel mode. To make the battery work properly, follow the instructions below to correctly connect it.

This chapter describes how to make cable and wires, and connect one battery and multiple batteries. If you have finished-cable and wires already, skip Section 6.1 and 6.2. Otherwise, read 6.1 and 6.2 carefully.

6.1 Power Terminals and Network Ports

The battery provides the following three network ports and two power terminals for electrical connection.

Table 6-1 Pin definition of network ports

Pin No.	PCS	Link-In	Link-Out
1	RS485_B	CAN2_H	CAN2_H
2	RS485_A	CAN2_L	CAN2_L
3	NA	Ecode_IN+	Ecode_OUT+
4	CAN0_H	ISO_GND	ISO_GND
5	CAN0_L	Master IN	Slave IN
6	NA	Dry1-	Dry1-
7	PCS_WAKE-	Dry1+	Dry1+
8	PCS_WAKE+	Syn_Wake In/Out	Syn_Wake In/Out

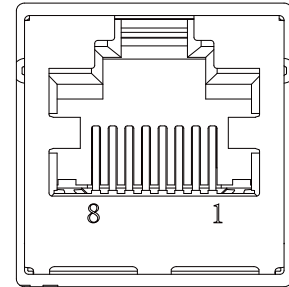
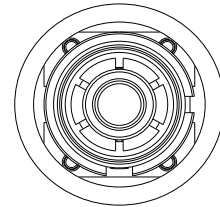

Table 6-2 Power terminals

Terminal	Description	Specifications	Cable Cross-section
+	Positive terminal 1	Max. 120A	25 mm ²
-	Negative terminal 1	Max. 120A	25 mm ²



6.2 Prepare Cables

Before connecting the batteries, prepare cables that meet the requirements of your applications.



CAUTION

Unqualified power wires might result in damages to the battery and your power system.

If you make cables on your own, please ensure that the terminals are crimped properly.

Step 1. Make power wires.

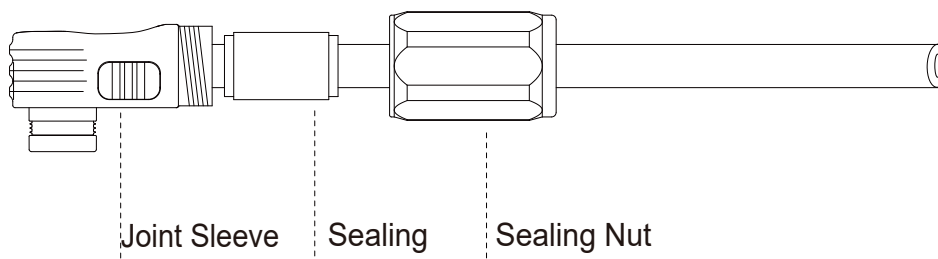

- Strip cable sheaths for 20 ± 0.5 mm. Insert sealing and sealing nut along the cable as shown. Orange is for positive power connection and black is for negative power connection.

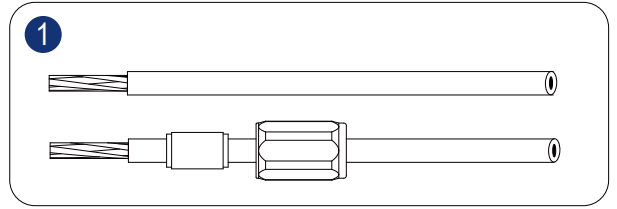

- Insert the copper wires into the joint sleeve.

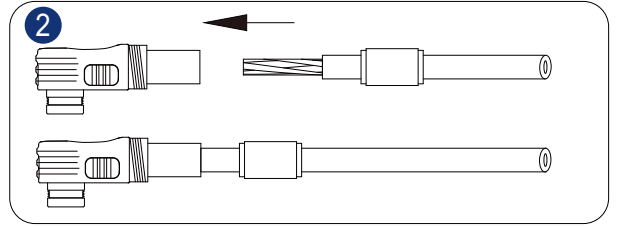

- Press connecting part with a hydraulic clamp.

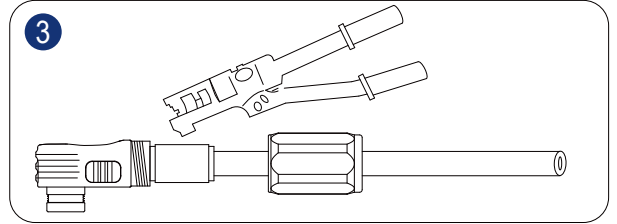

- Tighten up sealing, sealing nut and joint sleeve.

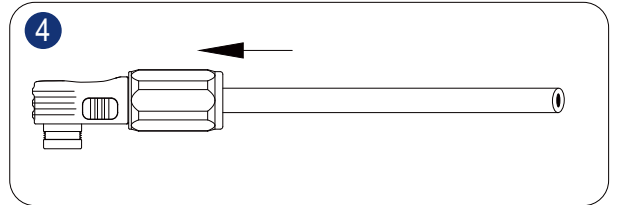

Step 2. Make Network Cable A.

- Strip cable sheaths for 15 ± 0.5 mm first.

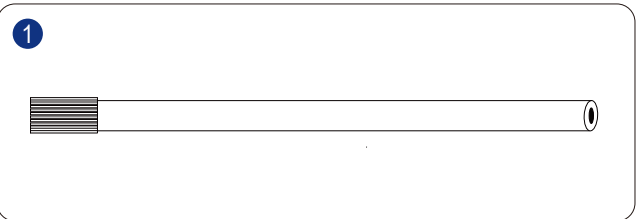

- Insert eight wires into an RJ45 plug at one end of network cable A. Ensure all wires stay well aligned.

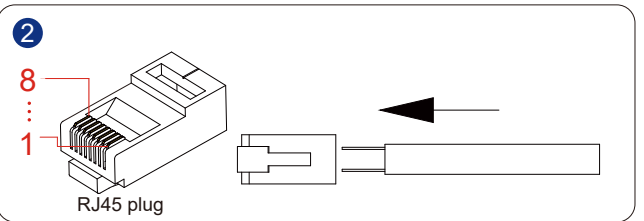

- Crimp the RJ45 plug with a wire crimper.

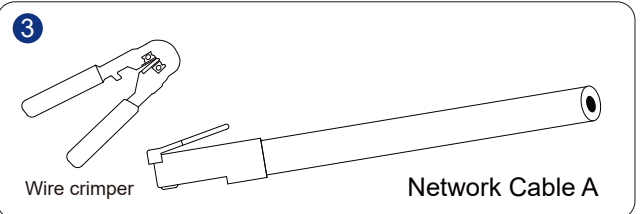

Step 3. Make straight through network cable B.

1. Strip cable sheaths for 15 ± 0.5 mm first.
2. Insert eight wires into RJ45 plugs. Ensure that the colors of wires stay consistent at both ends of network cable B.
3. Crimp RJ45 plugs with a wire crimper.

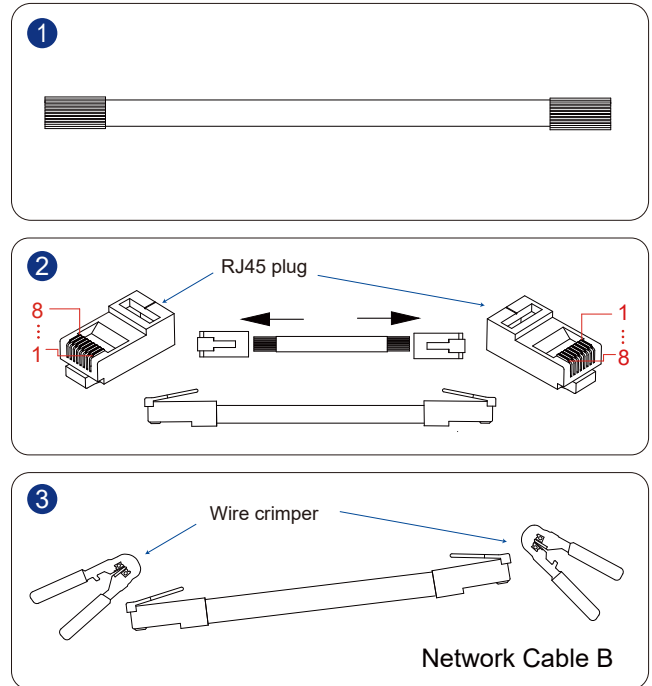

6.3 Connect One Battery



WARNING

- Before connecting the cables, ensure that the battery is in off mode.
- Wear protection equipment when wiring batteries.
- Ensure all cables are smooth and not twisted.

Keep the battery in off mode and connect it in the following way:

Step 1. Connect network cable.

1. Plug one end of Network Cable A into the **PCS** port of the battery and the other end into the network port of PCS.
2. Insert two terminators (a crystal plug with pin 4 and pin 5 short circuited) into **Link-Out** and **Link-In** respectively.

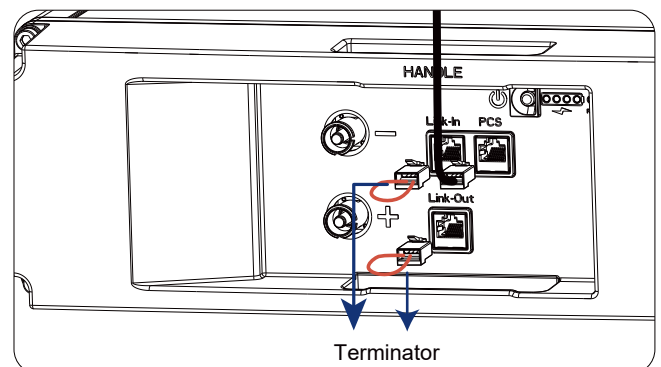

Step 2. Connect power wires.

1. Use the positive power wire to connect the + port of battery and PCS.
2. Use the negative power wire to connect the - port of battery and PCS.

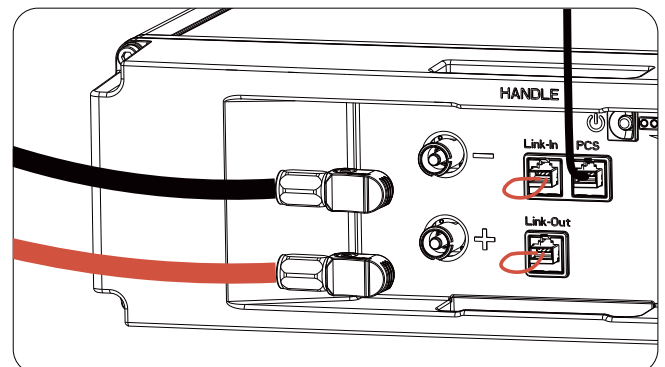

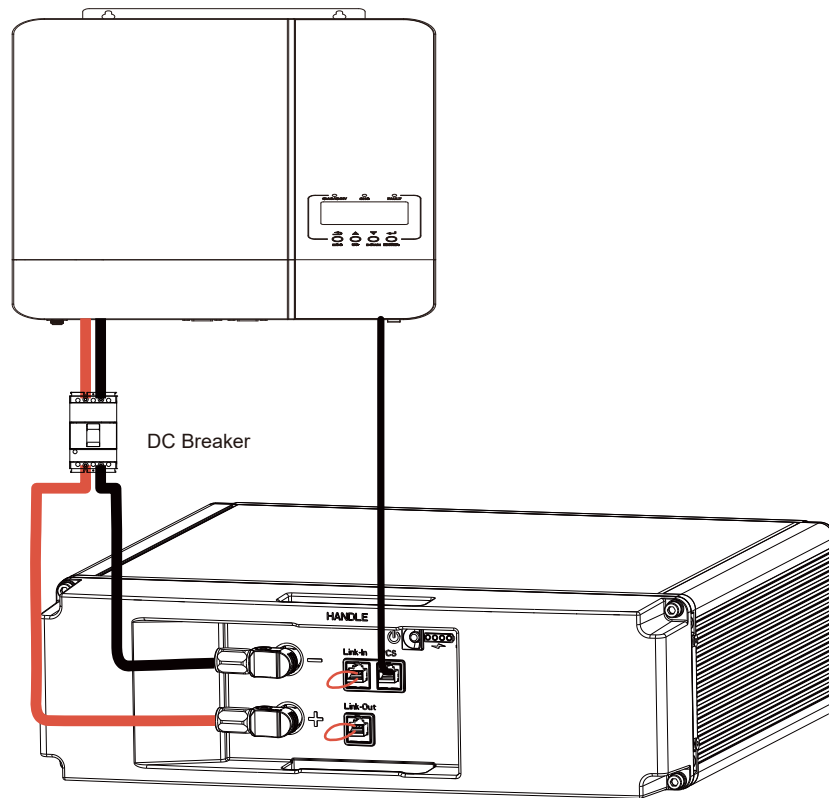

WARNING

- Install a breaker between battery and PCS to control the main circuit during installation, wire connection and maintenance.
- The breaker must be operated manually without using any tool and should be located near the battery.
- The distance between battery and the breaker should comply with local regulations.

6.4 Connect Batteries in Parallel

To increase the available amount of current and capacity, connect batteries in parallel. At most 8 pcs of batteries can be connected in parallel.



WARNING

Batteries in parallel should not have a cycle difference more than 300.

Step 1. Before installing and connecting the batteries, ensure that the voltage difference is not greater than 1V between batteries to be paralleled.

1. Power the batteries on and use a multi-meter to measure their voltages.
2. Charge the battery with lower voltage or discharge the battery with higher voltage if voltage difference is greater than 1V.
3. Power off all batteries and keep them in off mode.

Step 2. Connect network cables.

1. Plug one end of Network Cable A into the **PCS** port of battery 1 and the other end into PCS.
2. Insert a terminator (a crystal plug with pin 4 and pin 5 short circuited) into the **Link-In** port of battery 1.
3. Plug one end of Network Cable B into the **Link-Out** port of the first battery, and the other end into **Link-In** port of the second battery. The process goes on until the last battery is connected.
4. Insert a terminator (a crystal plug with pin 4 and pin 5 short circuited) into the **Link-Out** port of battery n ($n \leq 6$).

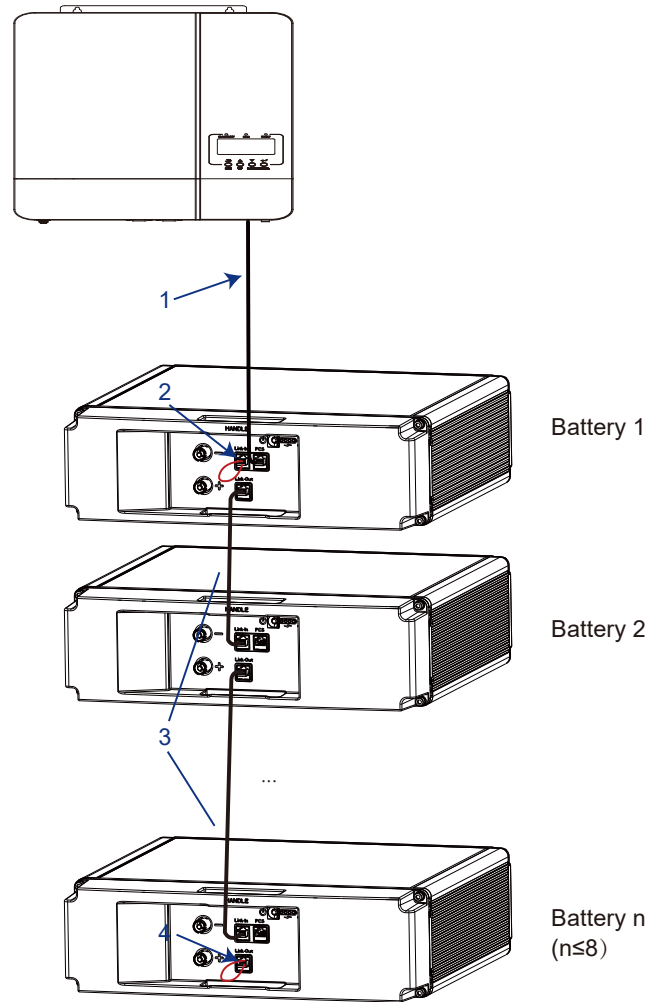

Step 3. Connect power cables.

1. Use a positive power cable to connect the + port of battery and junction box.
2. Use a negative power cable to connect the - port of battery and junction box.

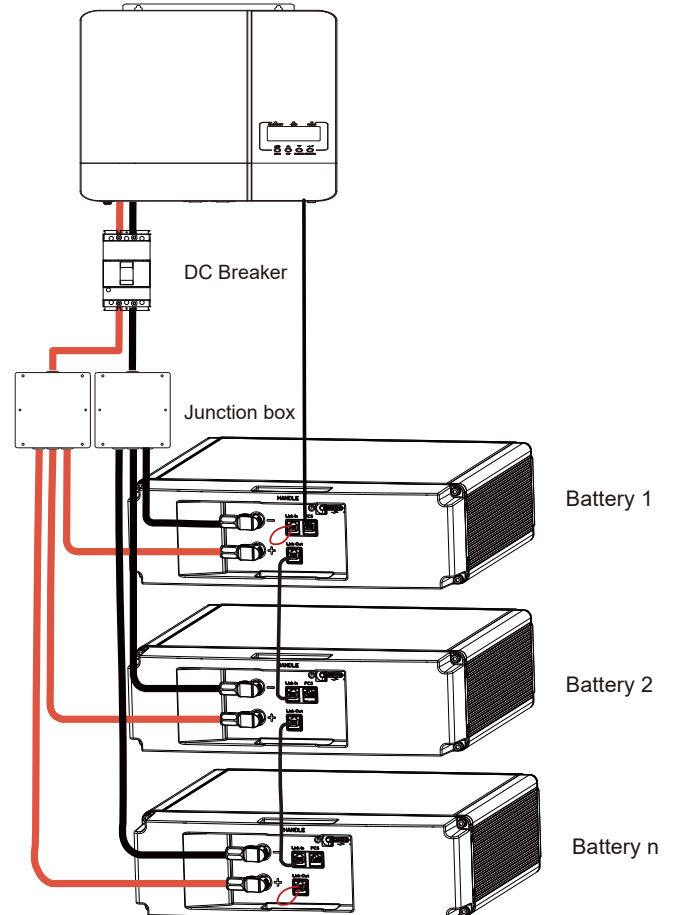

7 Operation



When operating or maintain the battery module, please strictly follow the safety instruction below:

- You must be a technician who goes through technical training and obtains certificates in compliance with local laws and regulations.
- Please stand on dry insulating objects and do not wear metal objects such as watches, rings and necklaces during operation.
- Use insulating tools and wear protective devices.
- Do not contact with two charged positions with a potential difference.
- Hang a prohibition sign that stop people approaching the equipment.
- Measure battery voltage with a multi-meter and ensure voltage output under off mode is 0V.
- If any abnormality is detected, immediately power off the battery. Proceed again only after causes are confirmed.

7.1 Power on Battery

The battery can be powered on by either charging voltage or the POWER button.

- Supply a charging voltage ranging from 33V to 60V, and battery(s) powers on.
- Hold the POWER button for three seconds.



If the SOC indicators turn on and the RUN indicator flickers for five times, batteries are powered on successfully and the communication between batteries works.

If the ALM light of one battery turns on (LED5 in red), there is a parallel connection failure and should be fixed before powering on batteries again.

7.2 Power off Battery

- Hold the POWER button of any battery for three seconds.
Five LED lights will flicker for three times, and battery turns off.
- Turn off the PCS, and the battery is powered off too.

8 Maintenance

Prepare tools like safety gloves, cross-head screwdriver and socket wrench.



Only professionals can conduct the battery maintenance.

8.1 Replace Battery



- Ensure undamaged appearance and complete accessories of new battery.
 - Do not change battery in rainy or stormy days.
 - Turn on the breaker and power off old battery;
 - Confirm wire connection of new battery, close breaker and power on new battery
-

When a battery is faulty or reaches its EOL, you might need to replace it with another one.

1. Wear safety gloves.
2. Turn on the breaker, and hold the POWER button for three seconds to power off battery.
3. Unplug power cables and network cables from battery terminals.
4. Loosen the screws the battery from the bracket.
5. Install a new battery.

8.2 Upgrade Firmware

Step 1. Install the BMS PC software.

1. Choose file **BMS Installation package.zip** and decompress it.
2. Enter BMS Installation package\Volume and double-click **setup.exe**.

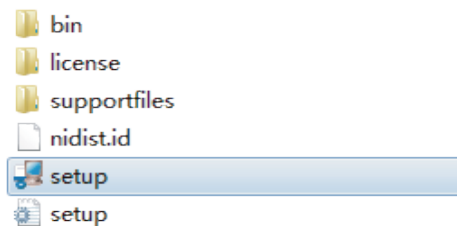

3. Keep the default configurations until completing the installation.

Step 2. Make sure the battery stays in IDLE mode or battery relays cut off.

Step 3. Connect computer and the PCS network port on battery with CANalyst-II.

Step 4. Perform upgrade.

1. Click Upgrade in the main menu of the BMS PC software.



- In the **Open device** dialog box, choose **CANalyst-II** from the **Device Type** dropdown list and **Extend** from the **Frame Type** dropdown list, and set **Baud Rate** to **500K**. Keep other default parameters. Click **OK**.

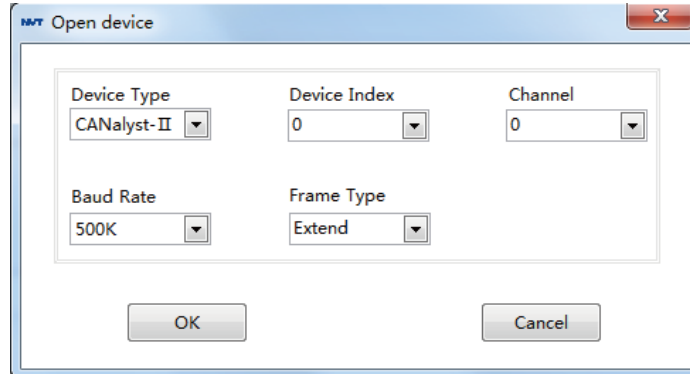

- Choose target upgrade file and click **Start Upgrade**. Upgrade succeeds when progress bar reaches 100%.

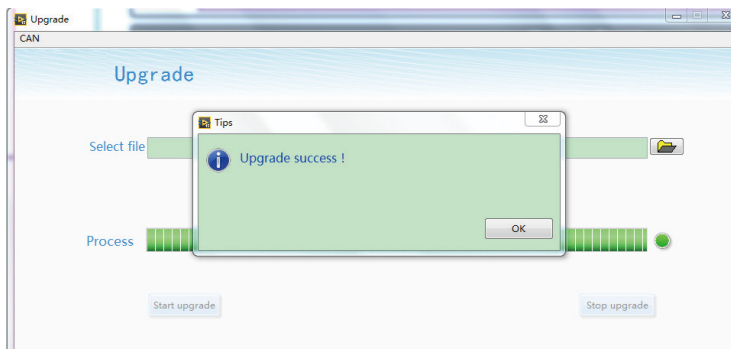

8.3 Troubleshooting

PACK Status	PACK Information	Display Logic					Remark	Duration
		LED1	LED2	LED3	LED4	LED5		
Remote		/	/	/	/	/	LED5 depending same as the normal status	/
Bootload		★	★	★	★	★	2Hz	1S-2S
Starting	Master/Slave	★	★	★	★	●	Master	3S~30S
		/	/	/	★	●	Slave 1	
		/	/	★	/	●	Slave 2	
		/	/	★	★	●	Slave 3	
		/	★	/	/	●	Slave 4	
		/	★	/	★	●	Slave 5	
		/	★	★	/	●	Slave 6	
Application Mode checking	Parallel or single application mode checking success	SOC Display				★	Blink 5 times	2S
Fault	Cell Over Voltage	/	/	/	/	●	LED5 depending on the previous status, blink 2 times, then shutdown	
Shutdown	/	★	★	★	★	★ or ★	Return after 10s	
Click	Display PACK ID	Display PACK ID				off	Return after 10s	

★: Blue LED Blink ●: Blue LED On ■: Blue LED flash display
 ★: Red LED Blink ●: Red LED On

9 Product Liability

DOWELL is not responsible for the incident caused by not obeying the Manual. Before using the battery, you should read the specifications, safety information and operation instructions carefully to learn its application method and scenarios. If the product or accessories are damaged by incorrect using method, wrong circuit connection, incorrect data settings, or working beyond limit defined in the Manual, DOWELL does not provide any warranty or assume any accountability for the injuries or loss.

10 Recycle

Lithium iron batteries are recyclable, valuable resources and should be recycled according to the local laws or regulations. Do NOT throw your battery into household waste.

For information on used batteries, contact the place of purchase or your battery distributor.