

SPRT®

KIOSK EMBEDDED UNIT USER'S MANUAL

(SP-EU806/EU807 Series)

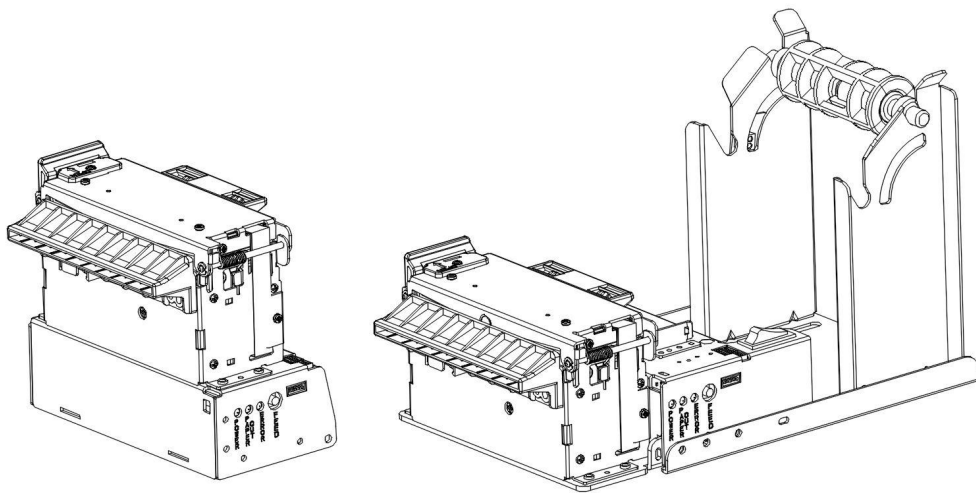

(Ver 1.04)

Beijing Spirit Technology Development Co., Ltd
www.sprt-printer.com

Safety Instruction

Safety warning

- 1) The print head is heating parts, during printing and end printing, do not touch the print head and surrounding parts.
- 2) Do not touch the surface of the print head and connection socket, avoid the electrostatic damage the print head.

Notice

- 1) Printing units should be installed in a flat, stable place;
- 2) Keeping enough space around the printing units to be convenient for operation and maintenance;
- 3) Far away from water for all printing units;
- 4) Do not use and store printing units in high temperature, damp and polluted places. Avoid sunlight, strong light and heat direct sources;
- 5) Avoid the printing units in the vibration and impact;
- 6) Avoid the damp air condensation on the surface of the printing units. If condensation has been formed, do not open the power of the printing units before the dew disappear;
- 7) Keep the printing units power adapter connected to a properly grounded outlet; avoid using the same socket with large motor or other devices which can lead to the power supply voltage fluctuation;
- 8) If long time will not use the printing units, please disconnect the power of the power adapter;
- 9) To avoid water or conductive material into the printing units interior, once occurred, should immediately shut off the power;
- 10) Printing units shall not be print under the conditions of no paper, otherwise will seriously damage the printing roller and the thermal print head;
- 11) In order to guarantee the print quality and the product life, suggest to use same quality paper as recommended;
- 12) In the case of print effect meets the requirement, suggest users to set lower level concentration of print as much as possible, to avoid affect the life of the print head;
- 13) The user shall not be removed printing units for maintenance.

Content

Safety Instruction.....	1
Brief Introduction.....	1
Models.....	1
Chapter 1 Characteristics and performance.....	2
1.1 Print performance.....	2
1.2 Print paper.....	2
1.3 Character set.....	2
1.4 Interface.....	3
1.5 Printing control command.....	3
1.6 Power supply.....	3
1.7 Outline Dimension and Installation Manual.....	4
1.8 Using of Paper Dam-Board.....	8
1.9 Work Environment.....	10
Chapter 2 Operating instructions.....	10
2.1 Printing Unit Components.....	11
2.2 Instructions for installing paper.....	13
2.2.1 Paper Loading.....	13
2.2.2 Solution for paper jam of cutter.....	14
2.2.3 Anti-blocking and Anti-pulling function.....	14
2.3 Interface connection.....	15
2.3.1 Serial interface connection.....	15
2.3.2 USB Interface.....	16
2.3.3 Power supply connection.....	16
2.4 Lights and buttons operation.....	17
2.5 Normal working mode.....	19
2.6 Self-test.....	19
2.7 HEX Printing mode.....	19
2.8 The printer parameters setting.....	20
2.9 Upgrading the printer program.....	20
2.10 Installation and use notes.....	21
Appendix A: Parameters setting.....	24

Brief Introduction

SP-EU806/EU807 printer is a new thermal line panel printer, with drop-in paper easy loading, auto cutter, Black label detection, faster and more reliable.

SP-EU806/EU807 printer easy operation, applications widely, especially to queue machine, POS for bank and the business of all kinds of needed docs to print.

Statement

This product is belong to class A. In the living environment, this product may cause radio Interference. In that case, the user need to take practical measures to interference.

Models

Model Name	Interface	With Bracket or not	Anti-pull and anti-jam function
SP-EU806SU	USB+RS232	/	/
SP-EU806SUMF	USB+RS232	/	SUPPORT
SP-EU807SU	USB+RS232	YES	/
SP- EU807SUMF	USB+RS232	YES	SUPPORT

Chapter 1 Characteristics and performance

1.1 Print performance

- Printing method: direct line thermal;
- Paper type: thermal paper;
- Printing paper width: 79.5 ± 0.5 mm (57.5 ± 0.5 mm, 82.5 ± 0.5 mm for choice)
- Resolution: 8dot/mm, 576dot/line (Option: 8dot/mm, 640dots/line)
- Printing speed: 150mm / s (max)
- MCBF: (1) Printing head life ≥ 100 km

Operating conditions:

* Print font 12 × 24 ASCII, printing 50 lines per time, Intermittent reprint.

* Thermal paper

(2) Auto cutter life: $\geq 1,500,000$ cuts.

- Effective printing width: 72mm

1.2 Print paper

- The mode of thermal paper: TF50KS—E (Japan paper co.ltd)

AF50KS-E (JUJO THERMAL)

• Thermal paper roll: Width ----- 79.5 ± 0.5 mm (57.5 ± 0.5 mm, 82.5 ± 0.5 mm for choice)

Thickness ----- 0.06-0.1mm (Normal thermal paper)

Paper roll diameter ----- 200mm (Max)

Diameter of paper shaft: 12.5mm and 24.5mm. The printing paper roll needs to match the paper shaft.

1.3 Character set

- ANK character set:

12×24dot, 1.5 (width) ×3.00 (high) mm

8×16 dot, 1.0 (width) ×2.00 (high) mm

9×17dot, 1.0 (width) ×2.00 (high) mm

- Chinese:

24×24dot, 3.00 (width) ×3.00 (high) mm

16×16dot, 2.00 (width) ×2.00 (high) mm

1.4 Interface

- PDK-5PIN serial port:

PDK-5PIN socket(pin point), support XON/XOFF and DTR/DSR.

Baud rate: 1200, 2400, 4800, 9600, 19200, 38400, 57600, 115200bps adjustable.

Data structure: One start bit + (7 or 8) data + one stop bit.

Verify: No validation or odd and even check is optional.

- USB port:

Standard USB port.

1.5 Printing control command

- Characters print command: support the double width and height printing of ANK characters, self-defined characters and Chinese; characters lines spacing can be adjusted.

- Bitmap print command: Support printing bitmaps with different density and downloaded graphics.

- GS bar code print command : support UPC-A, UPC-E, EAN-13, EAN-8, CODE39, ITF25, CODABAR, CODE93, CODE128, PDF417, QR Code, DATA Matrix bar code print.

1.6 Power supply

- DC24V±10%, 2A, VH3.96-2PIN power socket.

1.7 Outline Dimension and Installation Manual

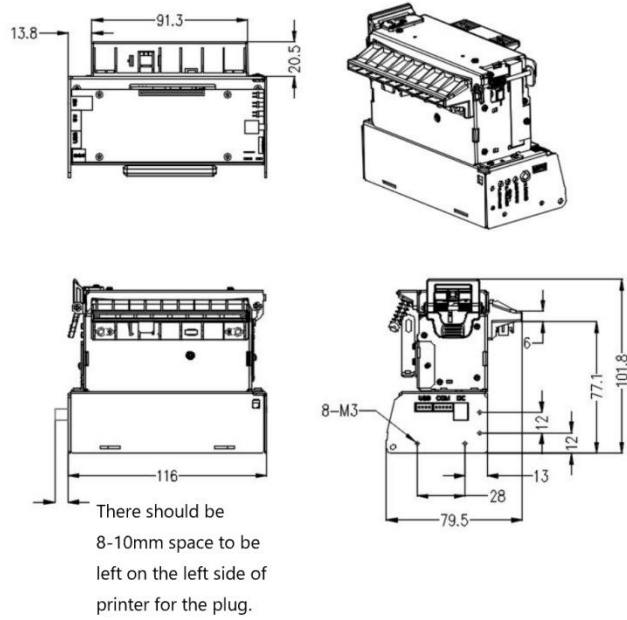

SP-EU806SU
(Standard)

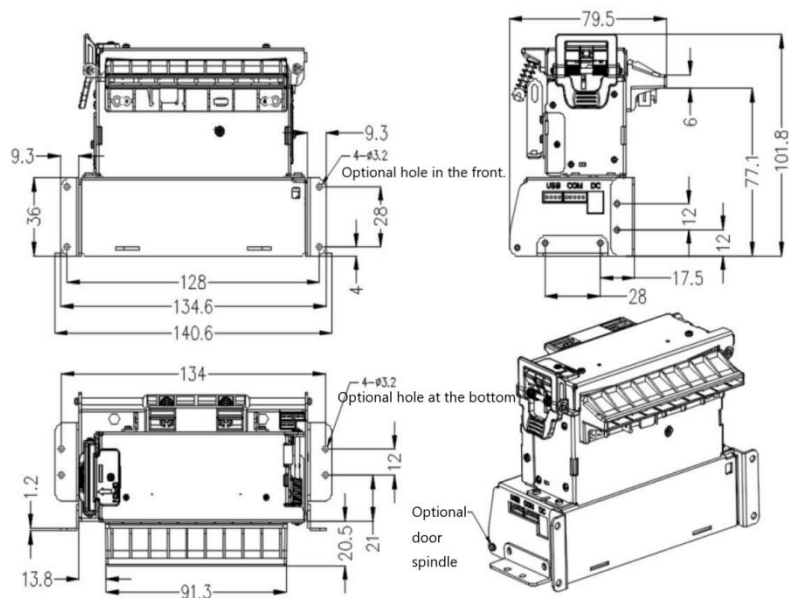

SP-EU806SU
(Optional Installation Board for the front or bottom side)

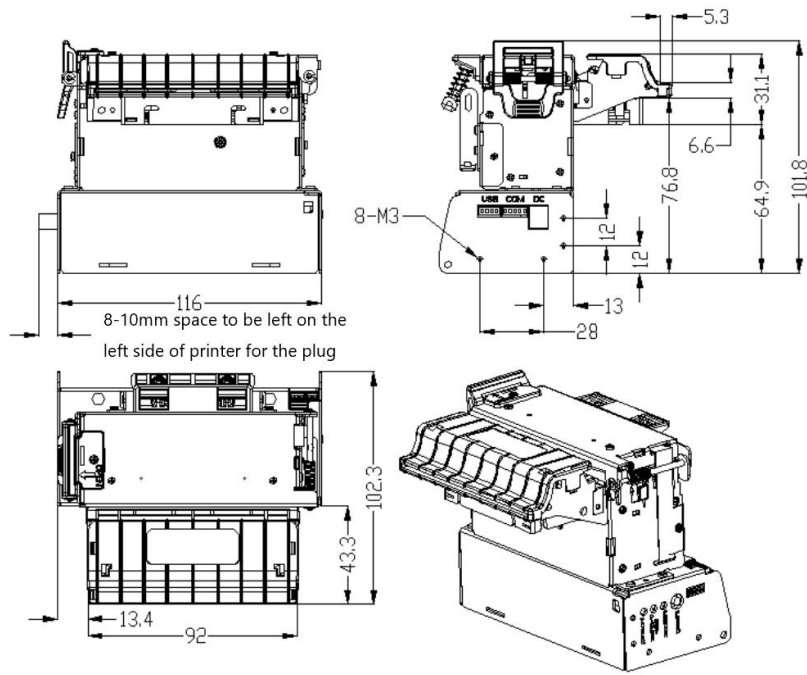

SP-EU806SUMF
(Standard)

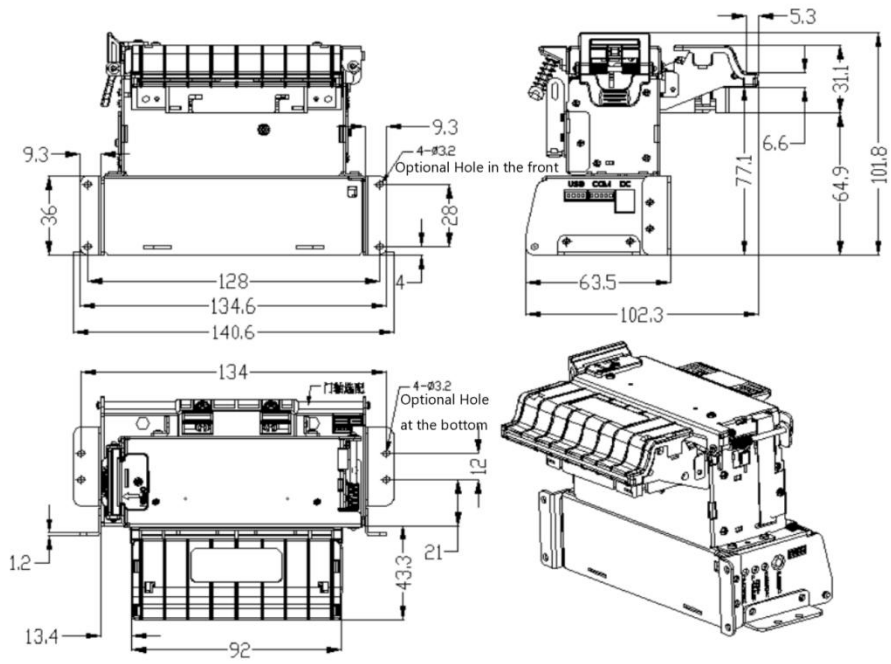

SP-EU806SUMF
(Optional Installation Board for the front or bottom side)

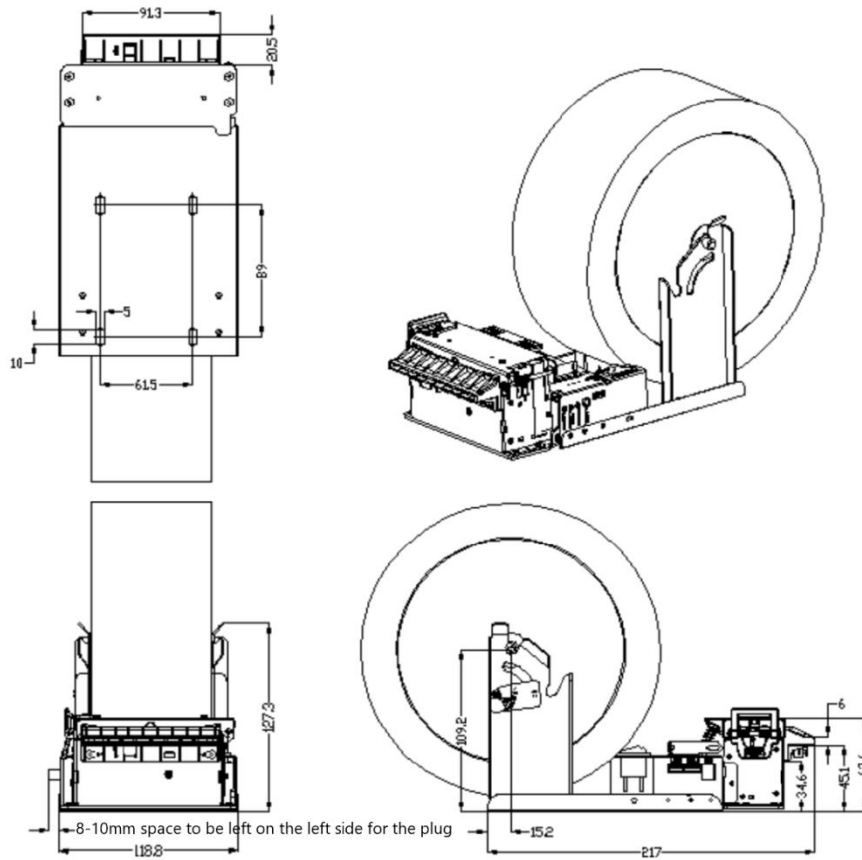

SP- EU807SU
(Standard)

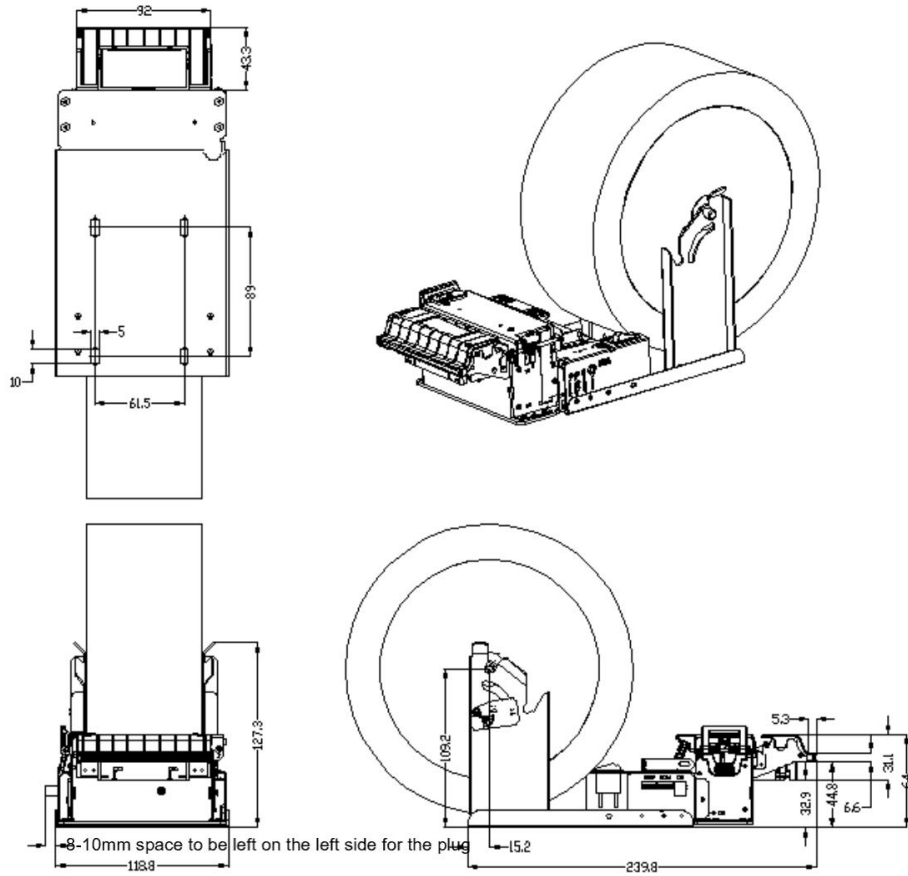

SP- EU807SUMF
(Standard)

1.8 Using of Paper Dam-Board

1. For the EU806 model, the paper input stopper is installed at a paper width of 80mm by default. If there are other optional paper rolls, the paper input stopper can also be installed at a position of 58mm or 82.5mm.
2. For the EU807 model, the default is to install at the 80mm paper width on the main support, and there is only one position.

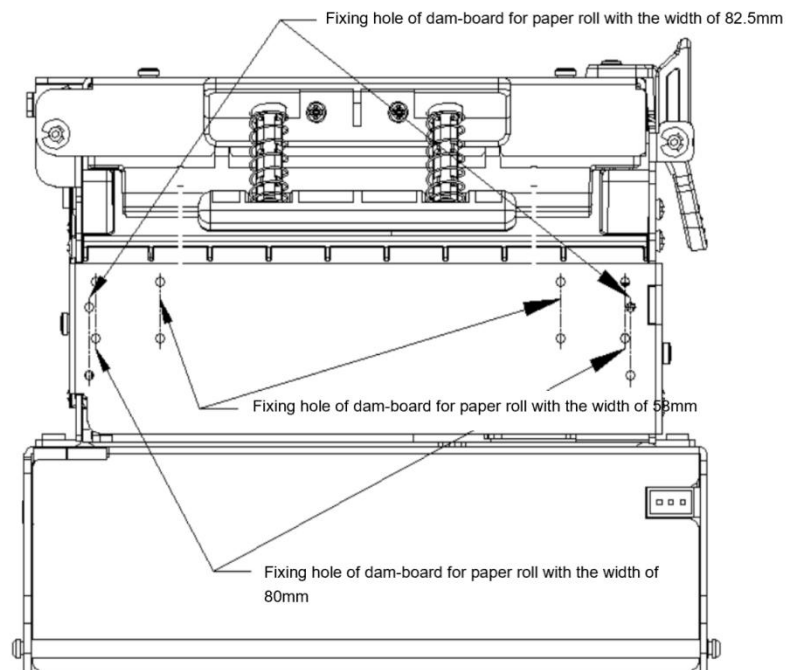

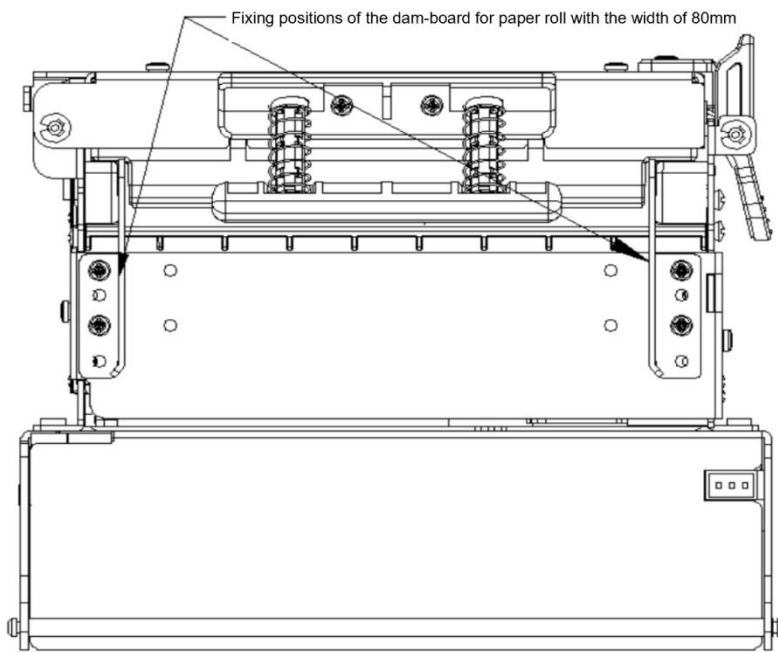
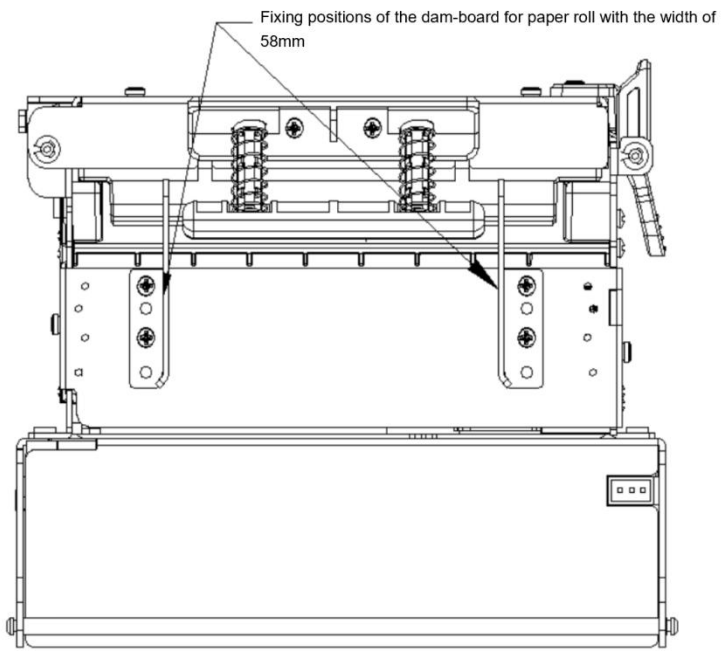

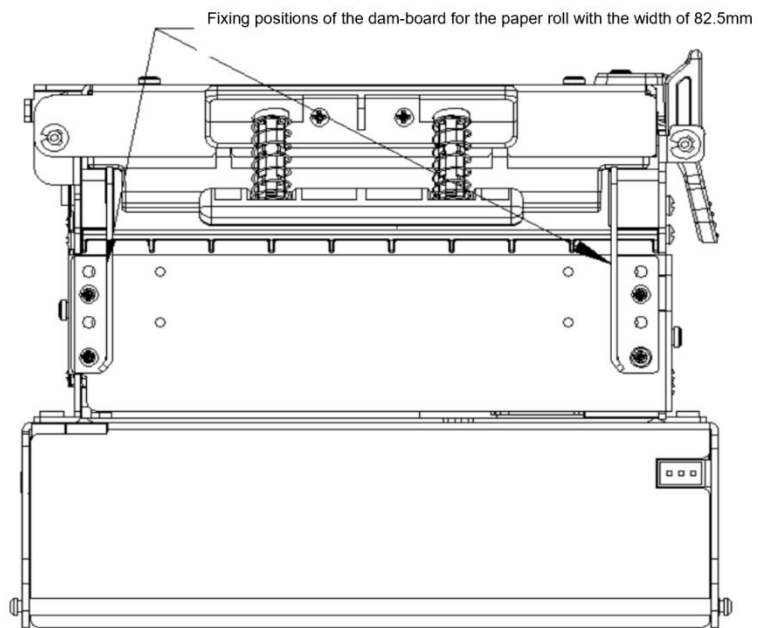

Diagram for the Using of Dam-board on EU806

1.9 Work Environment

- Working stability: 0 ~ 50°C Operating Relative Humidity: 10% ~ 80%
- Storage stability: -20 ~ 60°C Storage relative humidity: 10% ~ 90%

Chapter 2 Operating instructions

2.1 Printing Unit Components

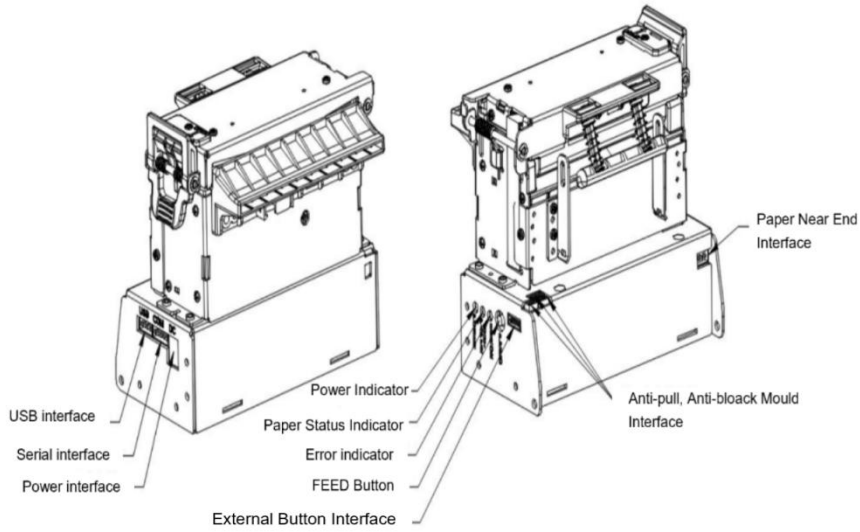

SP-EU806SU

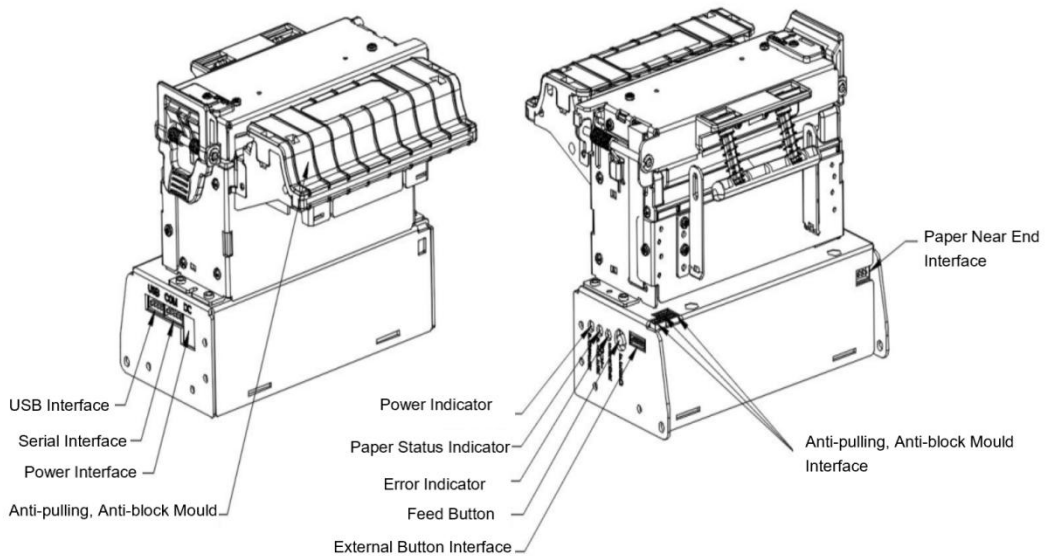

SP-EU806SUMF

(Attention: Please do load paper under the buffer shaft when loading paper.)

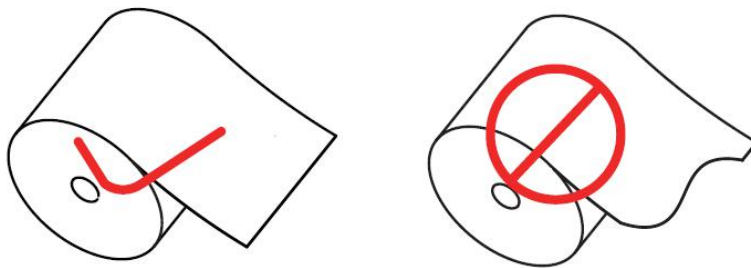
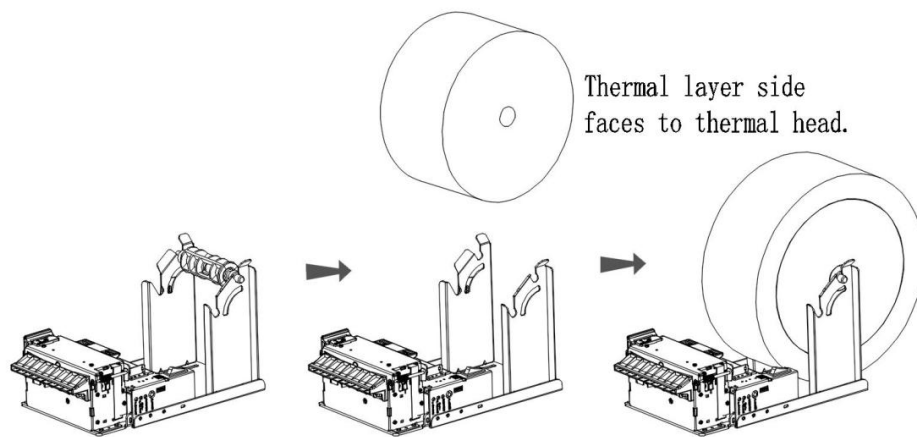

Attention: Please do ensure the paper to be flat when loading paper.



Attention

1. Pls pay attention to the paper direction. Make sure the thermal side of paper to face to the printing head.
2. Pls do not pull or push the paper by hand.
3. Pls make sure the printing head to be clean to ensure the printing quality.

2.2 Instructions for installing paper

2.2.1 Paper Loading

Thermal paper installed as below:

In the state of power-on, pull out a little from the paper roll, then put the paper into the mouth of printing mechanism, the printer will auto paper feeding .

(Notice: paper must be loaded from the below of buffer shaft)

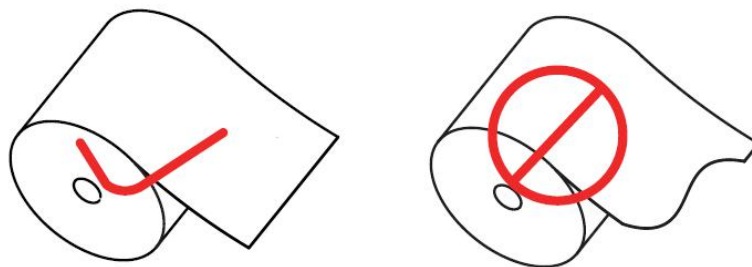
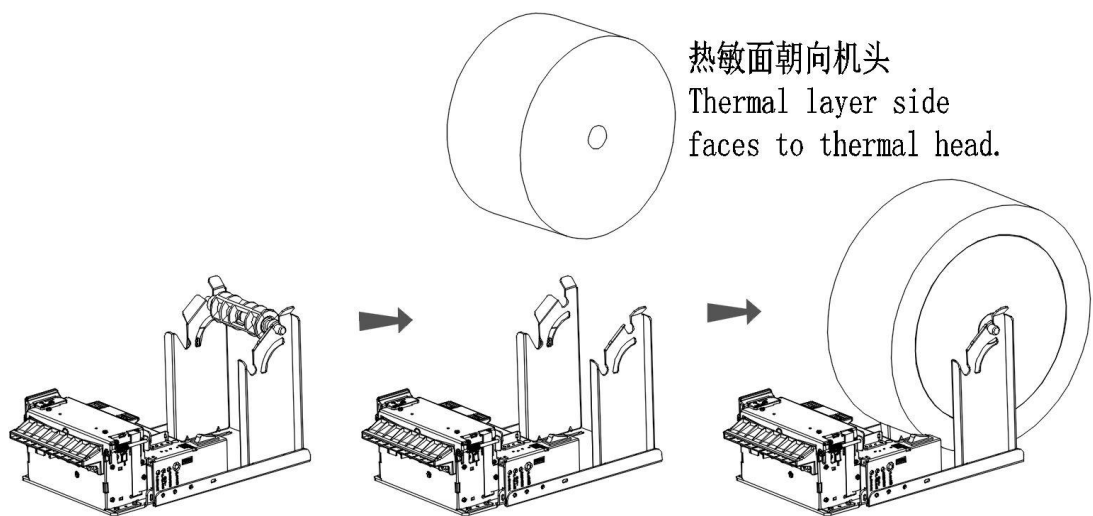

Note: make sure the paper is cut flat when loading.

△Attention

1. Pay attention to in the direction of the paper roll, keep the print surface towards the head.

2. Please do not move the paper forward or back by hands.

3. Keep clean for the printer head or will effect the quality of the Printing

2.2.2 Solution for paper jam of cutter

If the cutter is jammed, turn off the power and turn on the printer again, the cutter will recover.

2.2.3 Anti-blocking and Anti-pulling function

When the printer is working, users tear paper, pull paper or artificially jam paper. This type of operation triggers the printer's anti-blocking and anti-pulling function, as follows:

The users tear paper or pull paper will triggers the printer's anti-blocking and anti-pulling function, the printer will automatically cut paper to avoid other abnormal phenomena such as paper dislocation caused by tearing paper or pulling paper. After cutting the paper, it will automatically resume the normal printing state.

Artificial jam will triggers the printer's anti-blocking function. The printer will stop printing until there is no paper jam, and then it will automatically return to the normal printing state.

If the printer configured with the paper untaken function: after the completion of cutting, if the paper doesn't taken away, the anti-blocking and anti-pulling module will give a light alarm, and it will automatically return to the normal printing state until the paper has been taken away.

Note: it is necessary to confirm whether the no taking the paper function is supported. If so, when designing products, we need to consider a single get

application scenario to avoid not taking the paper then leads to not printing.

2.3 Interface connection

2.3.1 Serial interface connection

The serial interface of SP-EU806/EU807 printer is compatible with RS-232C, supports DTR/DSR and XON/XOFF handshaking protocol. PH-5PIN pin type socket can match it. The pin numbers of the serial interface socket as shown in figure 2-1:

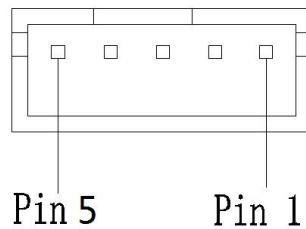

Each pin signal is defined as below:

Pin No.	Signal name	Signal direction	Source	Explain
1	RTS	output	printer	Same as pin 4 :DTR
2	TXD	output	printer	Printer send control code XON/XOFF and data to computer.
3	RXD	input	host	Printer receive data from computer
4	DTR	output	printer	When the signal show "MARK", it is means the printer is busy and can not receive data, when the signal show " SPACE", it is mean the printer get ready and can receive data.
5	GND	----	----	Signal ground

Mark: ① "Source" means the source of the signal

② Signal logic level for EIA

The baud rate and data structure have been set as 115200bps/8 data bits/no calibration and 1 stop bit under connected as serial. SP-EU806/SP-EU807 printer's serial interface can be connected to the standard of RS-232C interface. The correct wiring method is as shown in Figure 2-2.

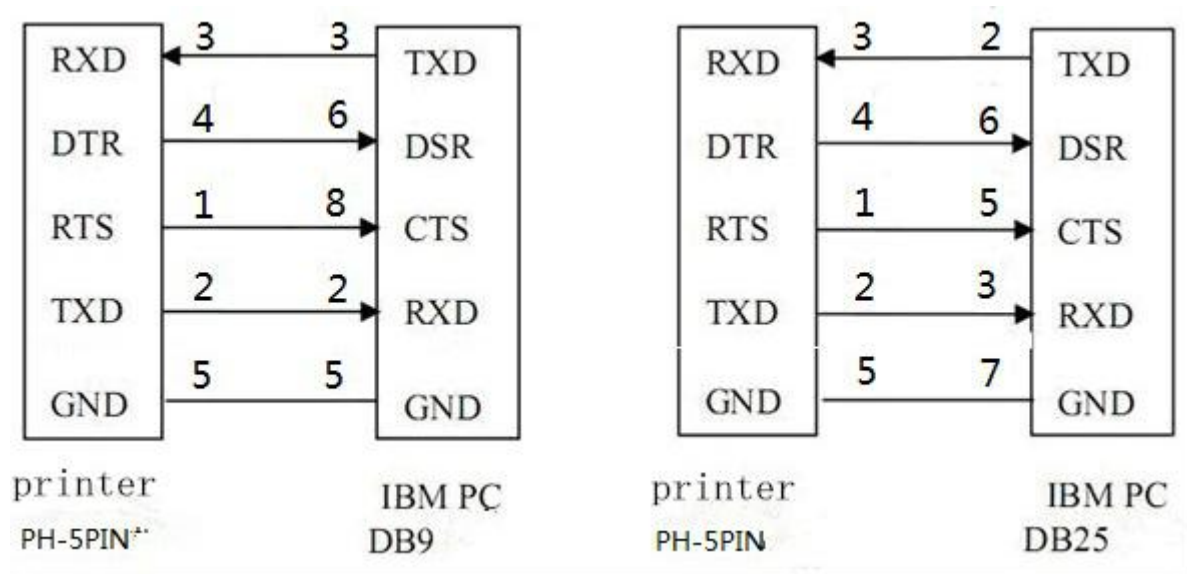

Figure 2-2: Printer serial interface and PC serial interface connection diagram

2.3.2 USB Interface

The USB interface of SP-EU806/EU807 is a PH-4A interface, the outline and pin definition are shown in the below figure 2-3

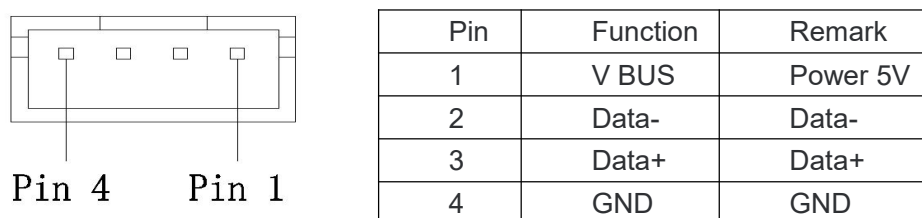
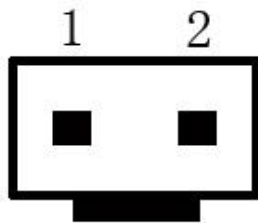

Fig 2-3 Definition of USB socket and pin

2.3.3 Power supply connection

SP-EU806/SP-EU807 printer is externally connected to 24V±10%, 2A power supply, and the socket is VH3.96-2PIN type. The shape and pin definition are shown in Figure 2-4.



Pin No.	Signal
1	+24VDC
2	GND

Fig 2-4 Definition of power socket and pin

2.4 Lights and buttons operation

SP-EU806/EU807 printer has one button and three lights.

【FEED】 button: It is paper feeding button, available to print commands allow or prohibit button switch function, in the condition of allow button control, press **【FEED】** button printer feeding paper, loosen **【FEED】** button, stop feeding paper.

【POWER】 indicator: It's green. POWER indicator lighting means printer has been switched on .

【PAPER OUT】 indicator: Paper status indicator, red; Light on or flashing indicates that the printer paper status is abnormal; When the printer is out of paper, the indicator light is always on. When the paper is about to run out, the indicator light flashes quickly. When the paper is jammed, the indicator light is at a certain frequency, see figure below.



【ERROR】 indicator: Error status indicator, red. When the printer works well, error light is off. The light flashes to indicate abnormal alarm status. When the indicator is long bright, it means the printing mechanism rubber roller opens on the process of printing.

The Error light flashes: means there are something wrong with printer.

According to blink in a different way, indicate the different types of printer error:

1, Non-recoverable error, the times of light flashes indicate the type of error, then the light will on for a period.

2, Recoverable errors, the times of light flashes indicate the type of error, then









the light will off for a period.

3, Automatic recovery error, the lights will flash continuous.

4, Out of paper, the light will long bright. When the printer roller opens, it will no longer test for a lack of printer paper, only check whether it has paper.

Shown as below:

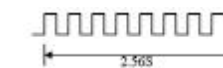
Non-recoverable error, the lights will flash for many times later will lighting for a period, then circulation, the times of the lights flashing show the errors type.

Error type	Error description	ERROR lights flash type
Non-recoverable error	LED flash once:Memory read error	
	LED flash two times:Over voltage	
	LED flash three times:Under voltage	
	LED flash four times:The CPU execution error (error address)	
	LED flash five times :UIB error	
	LED flash six times:FLASH write error	
	LED flash seven times:Write error parameter	
	LED eight times:Temperature detection circuit error	

a. Recoverable errors, the lights will flash continuous, then light-off for a period.

Error type	Error description	ERROR lights flash type
Recoverable errors	LED flash once :cutter position error	

b. Automatic recovery error, the lights will flash continuous. Including the print head temperature error and the upper cover to open the print process error.

Error type	ERROR lights flash type	ERROR lights flash type
Recoverable errors	LED flash continuous: the printer head is overheating, or open the wrong printing mechanism in the process of printing roller.	

2.5 Normal working mode

When printer is off, 【printing rubber roller】 is closed, then open the power button, Status indicators and paper out indicator shine alternately twice and then off, printer enter into the normal working mode.

2.6 Self-test

Self-test can detect the printer is working correctly or not, if it can print out self-test receipt correctly, it is mean everything is normal except the port connection with PCB board, or will be need repaired.

Self-test print out in sequence: name of manufacture,printer mode,software version,interface type,parameter default value of printer's,96 characters in the ASCII code,default code page content(set the language as English)or Chinese character name(if language set as Chinese),bar code type.

The self-test method is press the button of 【FEED】 to open the power supply, then the printer will print out the self-test receipt.

2.7 HEX Printing mode

According to below steps, make the printer enter into the HEX printing mode.

- 1, Open the rubber roller of printing agencies;
- 2, Press the button of 【FEED】 then open the power supply:
- 3,Close the rubber roller printing agencies, then print out three lines content as below:

Hexadecimal Dump

To terminate hexadecimal dump,
Press FEED button three times.

It means the printer has entered into HEX printing mode, under this mode all the input content will be printed out as HEX DUMP, the paper will advance after pressing the 【FEED】 button once, totally three times, print out "**** Completed ****", quit HEX DUMP mode.

2.8 The printer parameters setting

This function is to set up some simple parameters for the printer.

Enter into parameter setting method:

In shutdown mode, open the 【printing rubber roller】 first, press the button of 【FEED】, then open the power supply, after the status indicators and lack of paper lights flashing alternative

release the button of 【FEED】. Press the button of 【FEED】 twice again, then close the 【printing rubber roller】. The printer enters into parameter setting mode. And print out the first item of parameters and its current value which can be set. The details for setting method reference appendix A.

The method to quit the parameter setting

Open the 【printing rubber roller】 first, press the button of 【FEED】, then close the 【printing rubber roller】 and release the button of 【FEED】, save the setting values of the parameters and exit. Enter into the normal working mode.

If the printer's power supply is closed directly, the setting parameters will lose.

2.9 Upgrading the printer program

To upgrade the programmable hardware of printers with 【UpdateFirmware.exe】 tool, follow the instructions as shown below.



Instructions on the upgrading procedure:

1. Selecting the supported port on the transmission interface when the printer is in the standby status, click and switch it on.
2. Searching the dropping-down box and finding out the hardware documents need to be downloaded to the printers.
3. Pressing the initiating button to start upgrading.
4. The self-testing page will be printed automatically right after the upgrading.

2.10 Installation and use notes

1. The connection between the paper exit and the paper exit position of the device suggested to be one of the following figures.

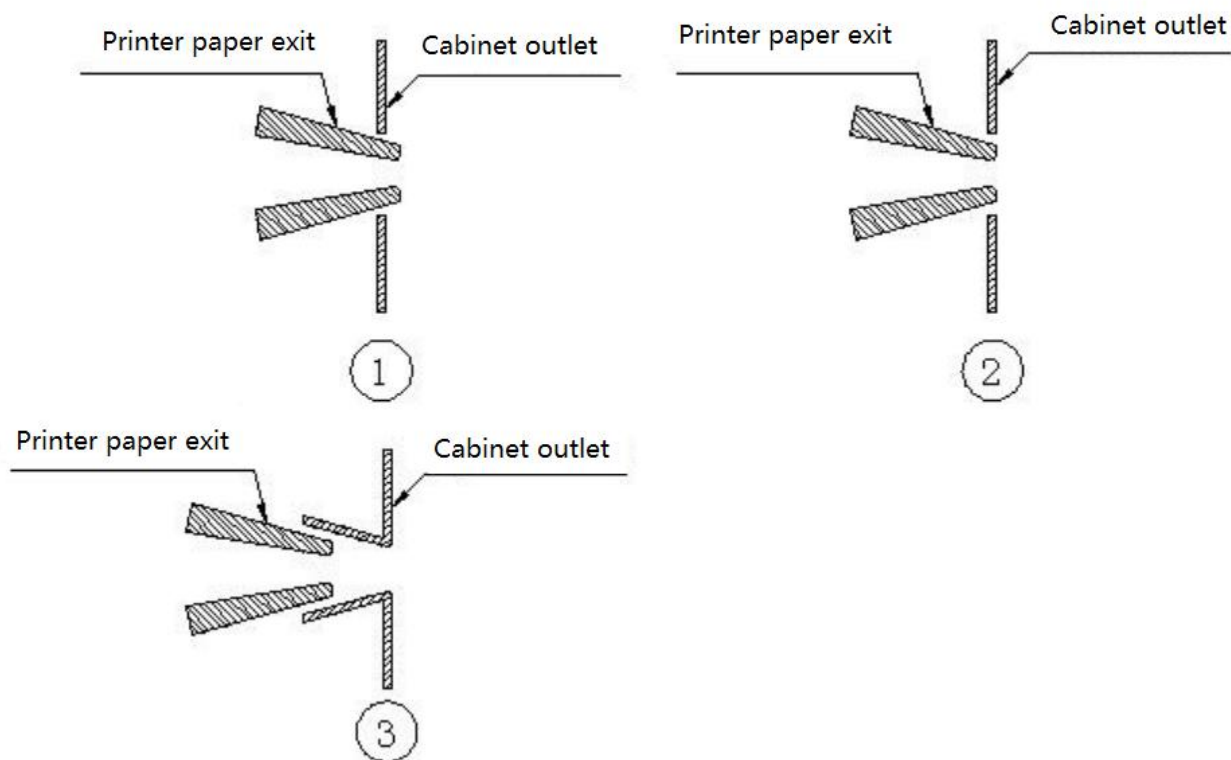

2. When the paper exit port and Cabinet outlet are connected in the above figure, in the structure of Figure 1 and Figure 2, there should be a gap between the paper exit of the printer and the paper exit of the device. See the figure below.

There is a certain gap between the paper exit and the equipment
(recommended one side 1-3mm, as shown in Figure A)

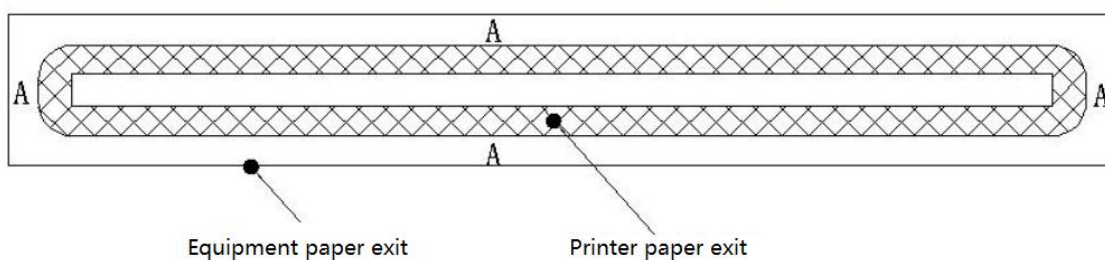

3. The printer must be firmly installed to prevent the printer from shifting due to external force and causing paper blockage. If installed on the sliding rail, it is necessary to make the sliding rail limit mechanism.

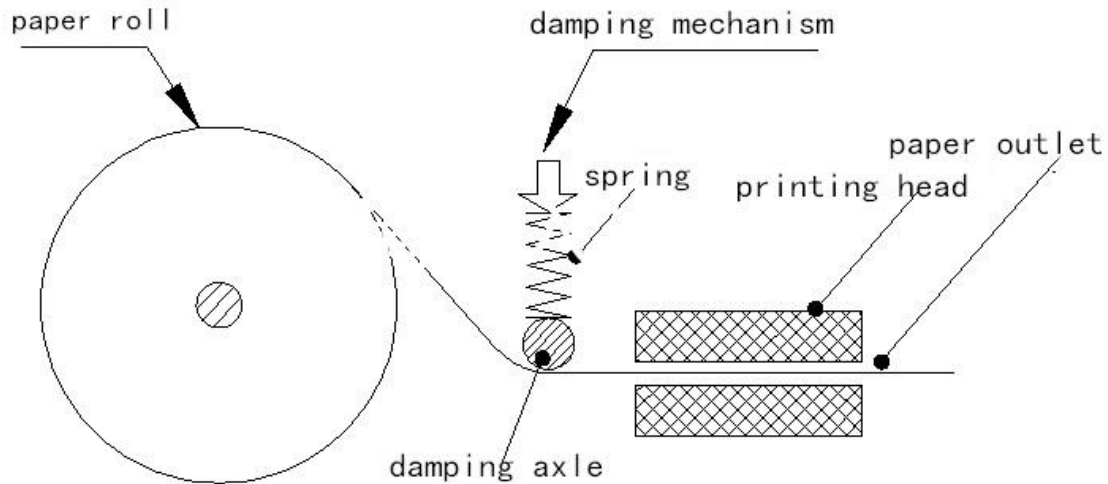

4. In the process of use, it is necessary to wait for the printer to finish cutting paper before tearing/taking paper, so as to avoid paper blocking and deviation caused by paper tearing.

5. In the process of use, do not cover the paper nozzle with your hands, and make sure there is no foreign body covering before the paper nozzle to avoid paper jam.

6. Ensure the paper head is flat and free from debris when loading the paper, so as to avoid slanting the paper or getting stuck in the machine head.

7. the printer is not suitable for working in the vibration environment, if you use the vibration environment, you must add damping design.

8. Printer in dust, oil, moisture, high temperature and other harsh environments, must do effective protection measures, so as not to affect the normal use of the printer.

Appendix A: Parameters setting

This appendix shows the way, through which printer's parameters are set through the button.

Setup instruction: use the button of **【printing rubber roller】** to choose the setting items, change the item by press the button **【printing rubber roller】** , and print out the current value. Use the button of **【FEED】** to set the parameter, the parameter will be changed by press the **【FEED】** button.

Full setting:

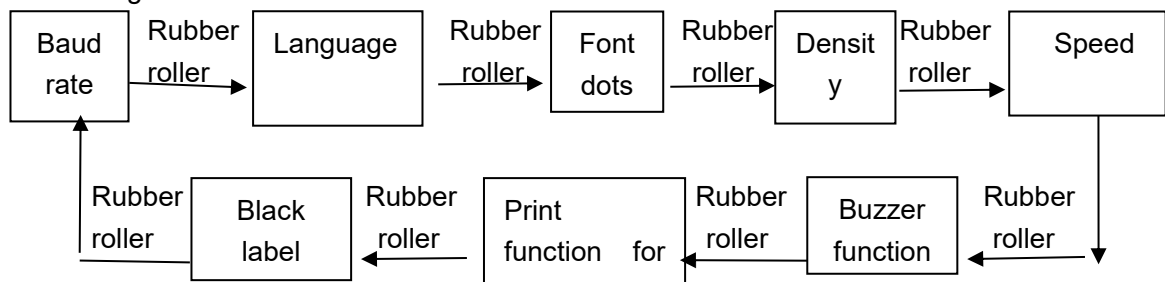

Baud rate:

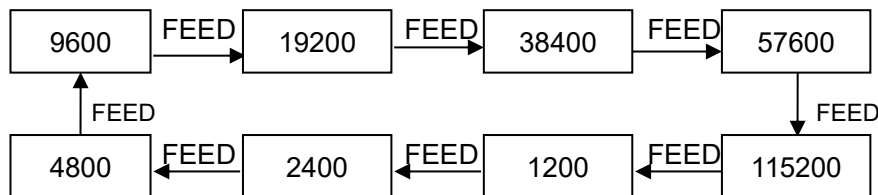

Language:



Font dots:

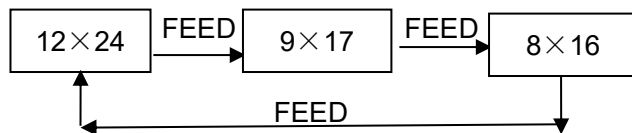

Print density:

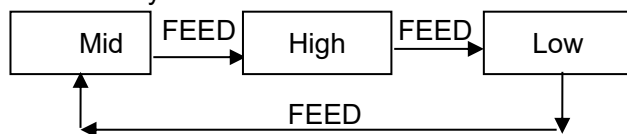

Print speed:

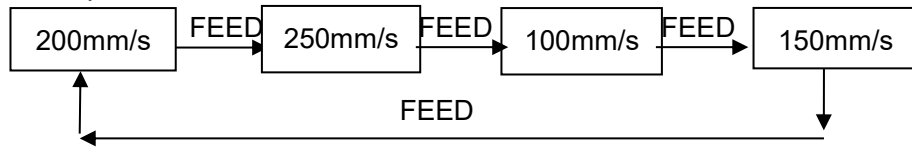

Black label mode:

