

SPRT®

SP-RMD8

Thermal Micro Panel Printer

User's Manual

Ver 1.08

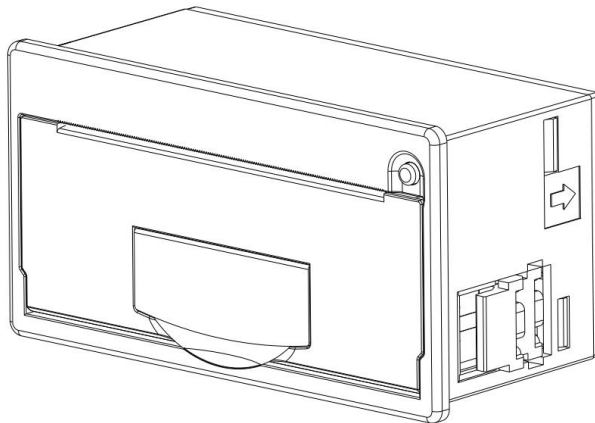

SP-RMD8A

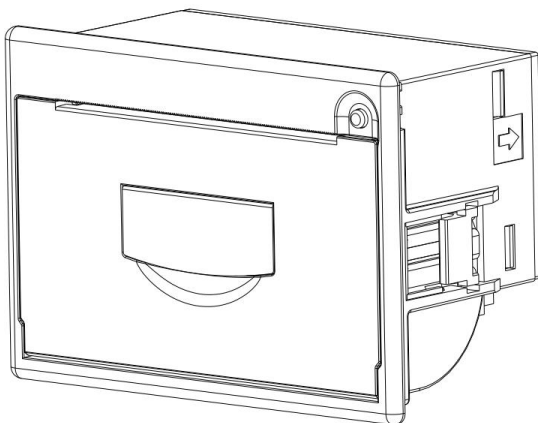

SP-RMD8B

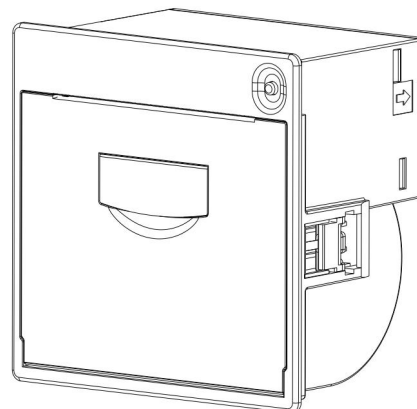

SP-RMD8C

Beijing Spirit Technology Development Co.,Ltd

www.sprt-printer.com

Content

Introduction	1
Chapter 1 Feature and Performance	2
1.1 Feature	2
1.2 Performance	2
Chapter 2 Printer Installation	3
2.1 Printer outline	3
2.2 Outline Dimension	4
2.3 Paper loading	5
2.4 Instruction of Mounting Installation Ear	6
Chapter 3 Operating Instruction	7
3.1 Interface connection	7
3.1.1 Serial interface connection	7
3.1.2 Parallel interface connection	10
3.1.3 USB Interface Connection	11
3.1.4 Printer Parameters Setting	12
3.1.5 Power connecting	12
3.2 Indicator and button	13
3.3 Self-test and Hex printing	13
3.4 Pinter Initialization	14
Chapter 4 Printing commands	15
4.1 Summary	15
4.2 Commands Description	15
4.2.1 Paper Feeding Commands	15
4.2.2 Format Setting Commands	16
4.2.3 Character Setting Commands	20
4.2.4 User-defined Character Setting Commands	24
4.2.5 Graphics Printing and Codepage Choosing Commands	26

4.2.6 Initialization Commands	29
4.2.7 Data Control Commands	29
4.2.8 Chinese Character Print Commands	30
4.2.9 Real-time Commands	33
4.2.10 Bar Code Printing Commands	34
Chapter 5 Using and Maintenance	40
5.1 Printing Head Maintenance	40
5.2 Other	40
Chapter 6 Printer Using under Windows	41
Appendix 1 Valid Codes Form under ANK printing	41
Appendix 2 Valid Codes Form under Chinese printing	43
Appendix 3 Printing Commands Form	44
Appendix 4 Example of MCU Interface	46

Introduction

RRMD8 thermal printer is a smart printer developed and produced by Beijing Spirit Technology Development Co., Ltd. for the 21st century. There are advantages of small volume, light weight, complete functions, fast speed, high definition, artistic appearance, simple operation, convenient connection. It is the most ideal matching product to use in medical equipment, fire-alarm control and other kinds of equipment, etc.

SP-RMD8 panel thermal printer has the same character set 1 and character set 2 as RMDIIB in the Western characters mode. In Chinese characters mode, it can print 12*24 half-width characters and 16 dots according to the Chinese character dot matrix. The 8*16 half-width characters of the array have Chinese characters, 24*24, 16*16, and the selection of the second-level fonts, as well as a large number of mathematical symbols, special symbols, graphics, and curves. Partial code characters can be customized by command to change the print line spacing and character size, with self-test function.

SP-RMD8 printer has Windows driver. It can print kinds of characters, Chinese and pictures directly through PC.

Chapter 1 Feature and Performance

1.1 Feature

- ◇ Thermal line printing.
- ◇ Printing head and circuit together to be convenient for installation.
- ◇ With single chip processor. There is standard parallel interface or serial interface, which is convenient to connect with kinds of microcomputers or intelligent equipment.
 - ◇ There is actual time printing command to print Characters, code, graphics, etc. The commands set is compatible with the traditional printer.
 - ◇ Support kinds of codepages and pre-saved bitmap printing.
 - ◇ Self-testing function. All codes can be printed, characters with high definition and beauty.
 - ◇ Enough receiving buffer 3K.
 - ◇ Front installation to be convenient for customers to install.
 - ◇ Printing paper: Width 57.5 ± 0.5 mm thermal paper.
 - ◇ Power request: Broad Input Voltage: DC5V~8.5V, 9V-24V Current: 3A.
 - ◇ Operating temperature: 0~50°C
 - ◇ Can be used in DOS and Windows.
 - ◇ 8dots/mm, 384dots/line.
 - ◇ Printing speed: 30mm/s.
 - ◇ Outline dimension(mm): W × H × D, please refer to figure 2-2~ figure 2-4 of chapter.

1.2 Performance

- ◇ Printing method: thermal line printing.
- ◇ Interface: Parallel (CENTRONICS compatible) , Mini USB B or Serial (RS-232 、 TTL or RS-485).

- ◇ Interface connector: IDE20pin plug socket for both serial and parallel interface.
- ◇ Universal ESC、FS、GS control code.
- ◇ LF button is controlling button for self-test and paper feeding. LF LED is indicator of error alarm and power. Different flickering frequency of indicator has different meanings, please refer to section 3.2 to learn more details.
- ◇ Printing paper: D8A:57.5×φ20mm(MAX); D8B:57.5×φ30mm(MAX); D8C:57.5×φ50mm(MAX)
- ◇ Reliability: MCBF (Average number of trouble-free rows) $(5\sim 15)\times 10^6$.
- ◇ TPH: 50KM
- ◇ Operating temperature: 0~50°C, relative humidity: 10~80%.
- ◇ Storage temperature: -20~50°C, relative humidity: 10~90%.

Chapter 2 Printer Installation

2.1 Printer outline

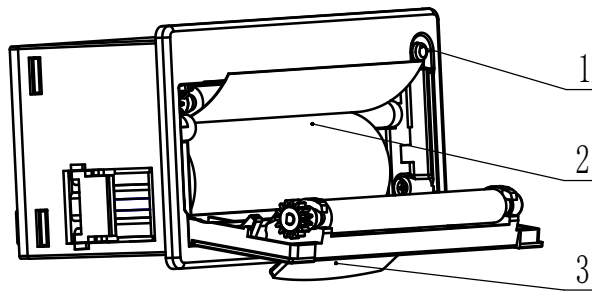

Picture 2-1

1. LF Button, Power indicator, Error indicator
2. Paper Roll
3. Open Door Handle

2.2 Outline Dimension

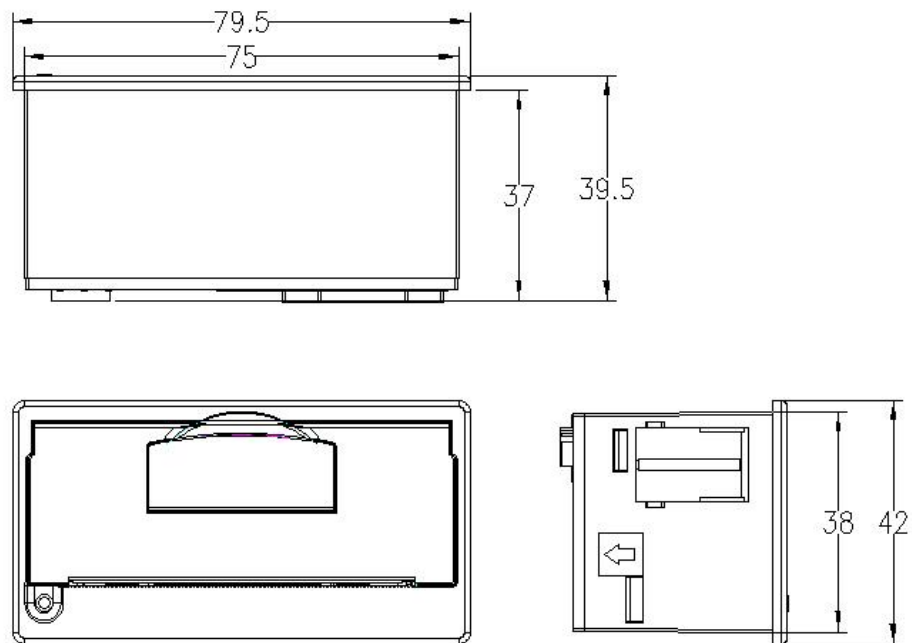

◇ Installation dimension: 75.5mm×38.5mm (W×H) depth:37mm

◇ Outline dimension: 79.5mm×42mm×39.5mm (W×H×D)

Picture 2-2 Outline & Installation dimension of SP-RMD8A

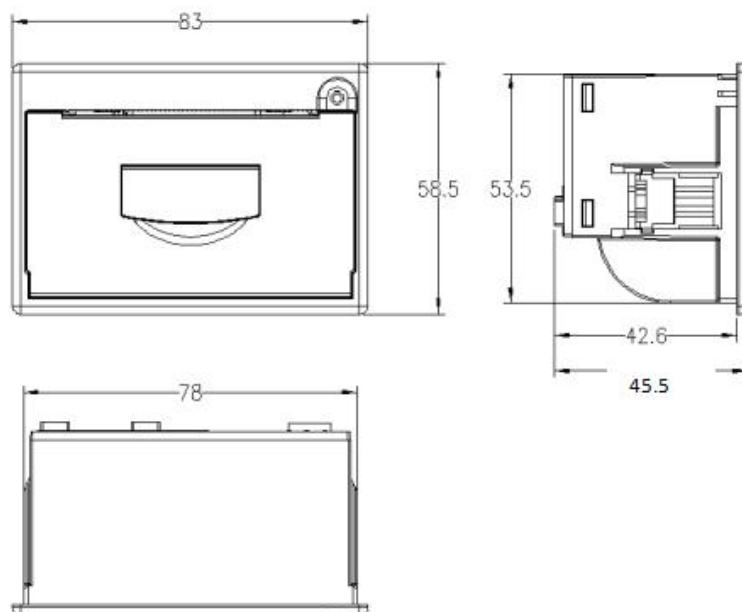

◇ Installation dimension: 78.5mm×54mm (W×H) depth:43mm

◇Outline dimension: 83mm×58.5mm×45.5mm (W×H×D)

Picture2-3 Outline & Installation dimension of SP-RMD8B

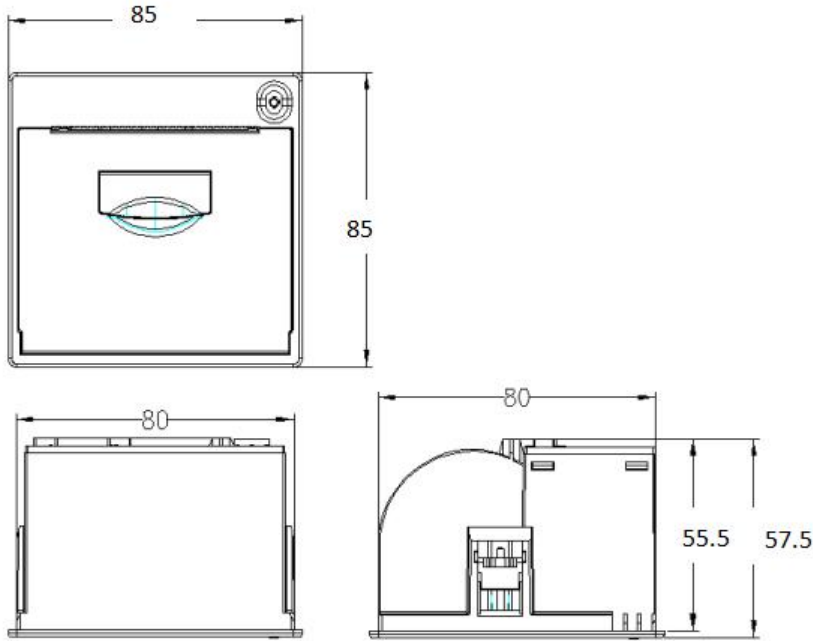

◇Installation size: 80.5mm×80.5mm (W×H) depth: 55.5mm

◇Outline dimension: 85mm×85mm×57.5mm (W×H×D)

Picture2-4 Outline & Installation dimension of SP-RMD8C

2.3 Paper loading

Pull the hand shank to open the paper case cover. Close the cover after loading the paper, as showed in Picture2-5.

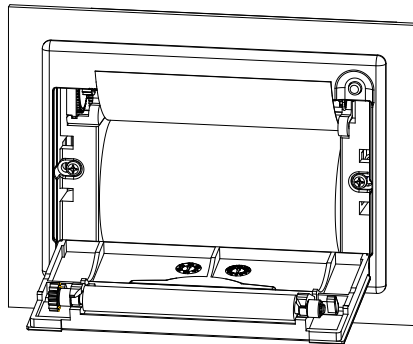

Picture 2-5

2.4 Instruction of Mounting Installation Ear

Put the printer into the installation hole of host panel at customer's side and open the paper case cover, as showed in Picture2-6. Then screw up the bolts in a clockwise direction until the installation ear moves to the position as showed in Picture2-7, the mounting finished.

Notice: Tightening force on bolts can not be over 2kgf·cm.

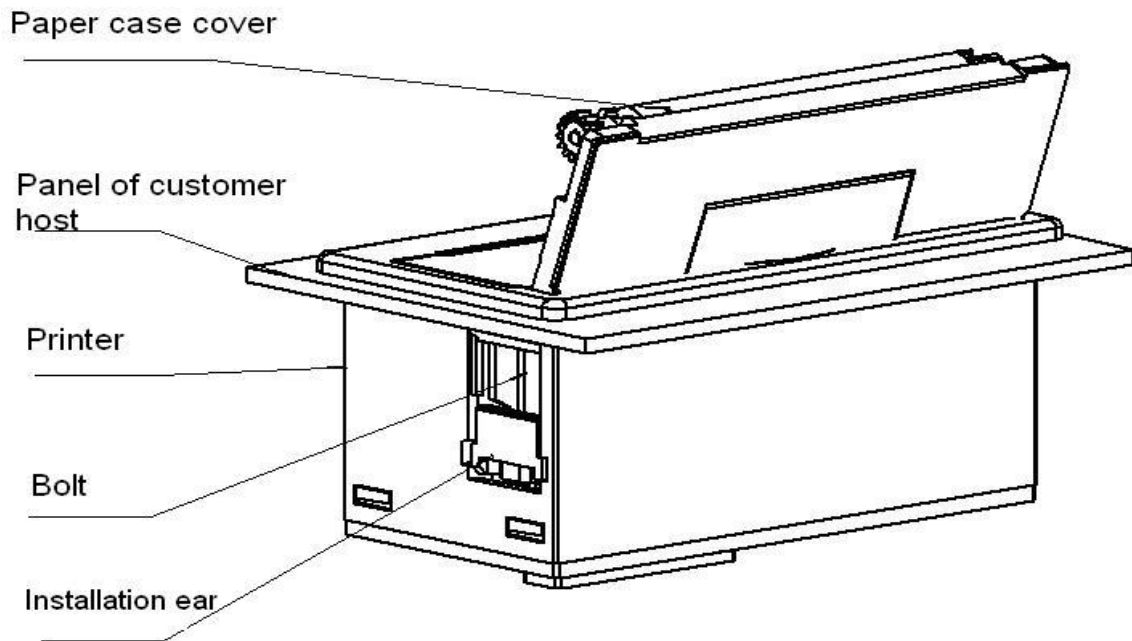

Picture 2-6

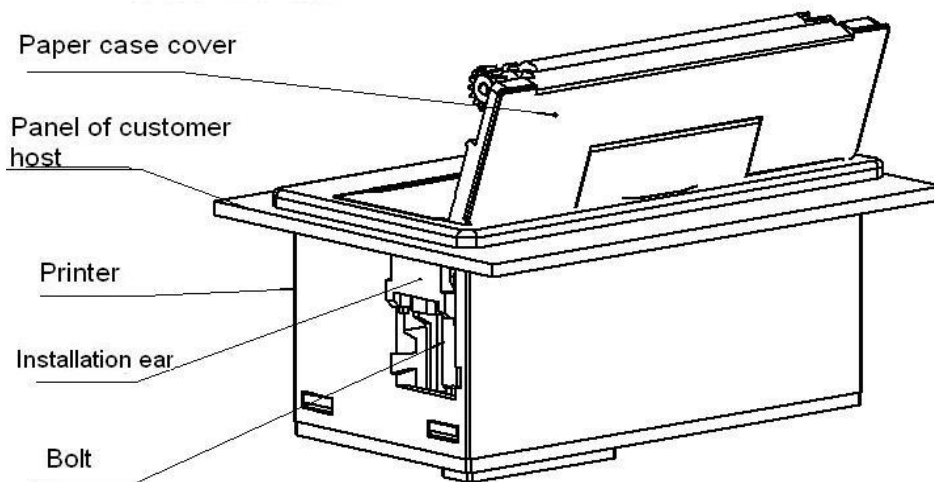

Picture 2-7

Chapter 3 Operating Instruction

3.1 Interface connection

3.1.1 Serial interface connection

The serial interface connection of SP-RMD8 is RS-232 interface, whose electrical level is EIA and TTL optional. RTS/CTS and XON/XOFF handshaking protocols are supported. The interface type is IDE20 pin type socket. The PIN assignment showed in Picture3-1:

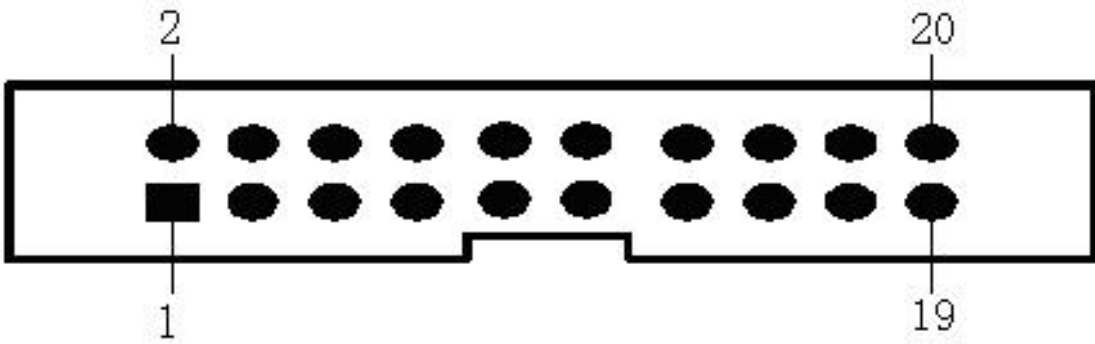

Picture 3-1 PIN assignment

When the electrical level of printer is TTL, the definition of pins is as showed in Picture3-2:

Signal name	Pin No. of IDE20 Socket	Source	Explanation
RXD	20	Host	Printer receives data from host
TXD	19	Printer	Printer send data to host. When X-ON/X-OFF handshaking protocol is used, printer send Control code X-ON/X-OFF to host.
CTS	18	Printer	When data is 1high, it means printer is too busy to receive data; when data is 0 low, it means printer is ready to receive data.
GND	2,6,8,12,16	—	Signal ground

Picture3-2 Definition of PIN assignment of serial interface

When the electrical level of printer is 232, the definition of pins is as showed in Picture3-3:

Signal name	Pin No. of IDE20 Socket	Source	Explanation
RXD	19	Host	Printer receive data from host
TXD	20	Printer	Printer send data to host. When X-ON/X-OFF handshaking protocol is used, printer send Control code X-ON/X-OFF to host.
DSR	15	Printer	This signal is "SPACE" status and means the printer is online.
CTS	18	Printer	When data is 1high, it means printer is too busy to receive data; when data is 0low, it means printer is ready to receive data.
GND	2,6,8,12,16	—	Signal ground

Picture3-3 Definition of PIN assignment of serial interface

If connecting post is two IDC- 10 type sockets, the functions and definitions of PIN assignment are same, the only difference is the electrical level, the definition explanation showed in picture 3-4, picture 3-5:

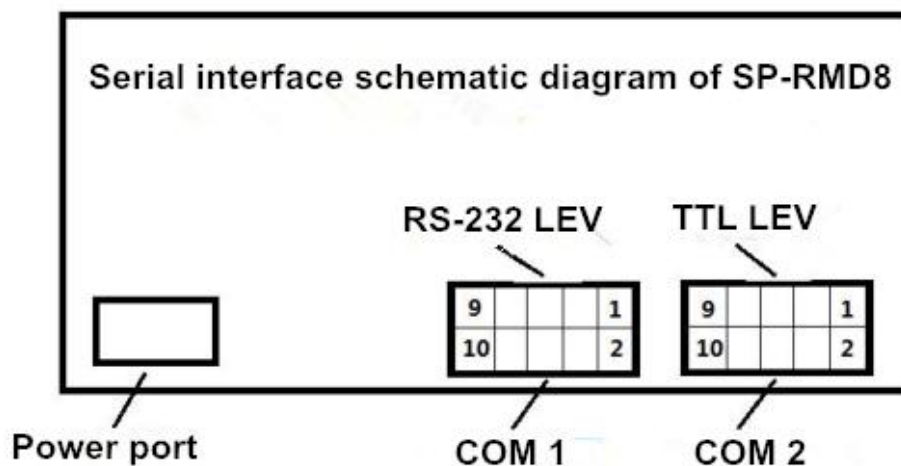

Picture 3-4 Definition of IDC-10 type socket

Notice: Please do not use these two COM port together.

Signal name	PIN Assignment	Source	Explanation
TXD	2	Printer	Printer sends data to host
RXD	3	Host	Printer receives data from host.
CTS	8	Printer	Flow control signal of printer and hardware of host (BUSY signal)
DRS	6	Pinter	Same with CTS
GND	5	—	

Picture 3-5 PIN Assignment of serial port

Notice: ① "Source" means where the source data comes from.

② Non-listed pin No. is empty pin.

③ 232 electrical level is negative logic. Negative electrical level means data 1; while positive electrical level means data 0.

When the electrical level is 485, the definition of pins is as showed in Picture3-6:

Signal name	Pin No. of IDE20 Socket	Pin No. of IDEC10Socket (COM 1)
A	20	7
B	19	9
GND	2,6,8,12,16	5

Picture 3-6 definition of PIN Assignment

Notice: ① Non-listed pin No. is empty pin.

During serial interface, baud rate and data structure can be set through Setting Tool software. Default factory setting is 9600bps, 8bits data bit, no parity and 1bit stop bit.

Baud rate support: 1200, 2400, 4800, 9600, 19200, 38400, 57600, 115200, etc, eight kinds.

There are two handshaking modes optional: One is Mark Control Handshake, the other is X-ON/X-OFF Protocol Handshake. The explanation of these two kinds is as showed in Picture 3-7:

Handshaking Mode	Data Direction	RS-232C interface signal
Mark Control	data can enter	"BUSY" signal line is in "SPACE" status
	data can't enter	"BUSY" signal line is in "MARK" status
X-ON/ X-OFF Control	data can enter	Send X-ON code "11H" on "TXD" signal line
	data can't enter	Send X-OFF code "13H" on "TXD" signal line

Picture3-7 Two handshake methods

3.1.2 Parallel interface connection

The parallel of SP-RMD8 printer is compatible with CENTRONICS standard, and the interface socket is 20-pin flat cable socket, or its substitute for connecting with it. The pin order of parallel port is showed as Picture3-8:

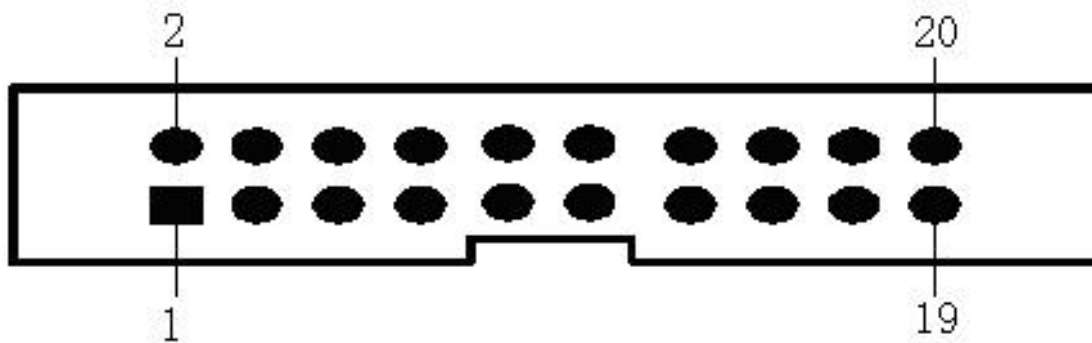

Picture3-8: Pin No. of parallel interface socket

The definition of each pin for parallel interface is as showed in Picture 3-9:

Pin No.	Signal	Direction	Explanation
1	/STB	In	Strobe pulse to latch data, reading occurs at rising edge.

3	DATA1	In	These signals represents the 1st bit to 8th bit of the parallel data representatively, each signal is at HIGH level when data is logic 1, and LOW when data is logic 0.
5	DATA2	In	
7	DATA3	In	
9	DATA4	In	
11	DATA5	In	
13	DATA6	In	
15	DATA7	In	
17	DATA8	In	
20	/ACK	Out	Answering pulse, LOW level signal indicates that data have already been received and the printer gets ready to receive the next data.
18	BUSY	Out	HIGH level signal indicates that the printer is BUSY and can not receive data.
19	/PE	Out	HIGH means printer is out of paper; LOW means there is paper
4	SEL	Out	It is raised to "HIGH" level through electric resistance and means the printer is ONLINE.
2、6、8	NC	---	Unconnected
10、12、16	GND	---	Ground-connected. The logic is "0" level.

Picture 3-9 Definition of parallel PIN assignment

Notice: ① “In” means sending into the printer;

“Out” means sending out from printer.

② The logic electrical level of signal is TTL electrical level.

3.1.3 USB Interface Connection

The SP-RMD8 printer has a Mini-USB interface, the appearance and definition of each pin assignment is as showed in Picture 3-10:



Pin	Function	Mark
1	V Bus	Power positive5V
2	Data-	Data-
3	Data+	Data+
4		Blank
5	GND	Grand

Picture3-10 Mini-USB interface & Definition of PIN assignment

3.1.4 Printer Parameters Setting

The parameters can be set through software:

“Setting Tool software” can be downloaded from our website. The detailed explanation can be checked from “Setting Tool software”.

3.1.5 Power connecting

SP-RMD8: Broad Input Voltage: DC5V~8.5V; Current: 3A

Power socket is like the following figure3-10, PIN assignment of power socket is like below figure 3-11:

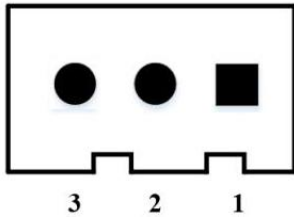

Figure 3-10 Power Socket Drawing

PIN Number	PIN Assignment	Instruction
1	VIN	Power Input
2	NC	NC
3	GND	GND

Figure 3-11 PIN Assignment for power socket

3.2 Indicator and button

The function of buttons will be different according to the different working mode of printer. In normal working mode, it is as below:

Paper feeding button (LF): When printer is power on, the button is “online” status. At this time, press 【LF】 button to feed paper; and loosen button to stop feeding paper.

The indicator for power and error is the same one. (Green)

Indicator status	Explanation
Persistent lighting	power on
Flicker once per second	Lack of paper. Recover to be normal after paper loading.
Flicker twice per second	Printing head over-heat. Recover automatically after the temperature of printing head falling.
Flicker three times per second	The heating plate of printing head broken. Unrecoverable. At this time, the printer needs to be repaired.

3.3 Self-test and Hex printing

Self-test can test whether the printer is normal working or not. If the self-test

receipt can be printed out correctly, it means the printer can work normally except the interface with host. Otherwise, the printer needs to be repaired.

The content printed on self-test receipt is Version No., Interface, Character and other configuration information.

The method of self-test is holding down 【LF】 button and turn on the printer. Then within three seconds, release the button. At this time, the printer will print out self-test receipt.

The method of HEX printing: is holding down 【LF】 button and turn on the printer. After the indicator flickers three times, loosen the button. The printer will print out “Hexadecimal Dump” and enters into Hex printing mode.

The method of quit hex printing: ① Press 【LF】 button constantly three times. Then send 0x00;

② Restart the printer directly

3.4 Pinter Initialization

There are two methods of printer initialization. One is that through the control code ESC @, the host sends commands to printer to initialize printer by commands. The other is restarting the printer.

Chapter 4 Printing commands

4.1 Summary

All the printing commands of SP-RMD8 are fully compatible with traditional ESC printing commands. The description form of each command is as following,

<u>Command name</u>	<u>Function</u>
Format: ASCII:	the standard ASCII character sequence
Decimal:	the Decimal number sequence
Hexadecimal:	the Hexadecimal number sequence

Explanation: the function of command and usage method

Example: some examples are listed to illustrate the command for better understanding.

The following is the description of each command according to the function of each command.

4.2 Commands Description

4.2.1 Paper Feeding Commands

<u>LF</u>	<u>Feed Line</u>
Format: ASCII:	LF
Decimal:	10
Hexadecimal:	0A

Explanation: The printer prints the current line and feeds paper forwards one line.

Remark: One line means the current character line.

<u>ESC J</u>	<u>n Dot Line Feed</u>
Format: ASCII:	ESC J n
Decimal:	27 74 n
Hexadecimal:	1B 4A n

Explanation:

The printer feeds paper n dot lines. n=1~255.

This command doesn't send carriage return and feed line. It won't influence the later feed line command.

If you need to feed paper immediately but no carriage return, can use ESC J command.

Line spacing will be enlarged automatically when using commands ESC V, ESC W and FS

W for enlarging characters.

ESC 1		Set n Dot-line Spacing		
Format:	ASCII:	ESC	1	n
	Decimal:	27	49	n
	Hexadecimal:	1B	31	n

Explanation:

The n dot-line spacing is set for future Line Feed command. n=0~255

Default setting n=3 for text printing, n=0 for bitmap printing when using ESC K command.

The BASIC programs for observing the effect of this command are as below:

```
FOR I=1 TO 11 STEP 2
LPRINT CHR$(27);CHR$(49);CHR$(I); ' ESC 1 set line spacing
LPRINT "RMWD TEST" ' Print character string and feed line
NEXT I
```

The print result of the above is as following:

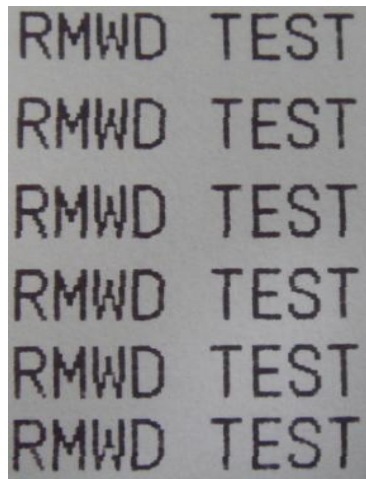

4.2.2 Format Setting Commands

ESC B		Set Vertical Tab Value			
Format:	ASCII:	ESC	B	n1 n2 n3...NUL	
	Decimal:	27	66	n1 n2 n3...0	
	Hexadecimal:	1B	42	n1 n2 n3...00	

Explanation:

The vertical tab positions are entered as n1, n2 and so on. Character NUL is added at the end to indicate that the command is over.

VT command is to carry out vertical tab and the paper is fed to the next vertical position. All input vertical tab positions can be deleted by using this command in ESC B NUL format.

Example: set three vertical tab values at 2nd line, 5th line, 8th line in one page, you can send the following commands:

ASCII:	ESC	B	STX	ENQ	BS	NUL
Decimal:	27	66	2	5	8	0
Hexadecimal:	1B	42	02	05	08	00

The BASIC programs about the above example are as below:

```

LPRINT CHR$(27); "B"; CHR$(2); CHR$(5); CHR$(8); CHR$(0); 'ESC   B command
      LPRINT CHR$(11);                                     'VT command
      LPRINT "SPRM1";                                     'print character string
      LPRINT CHR$(11);                                     'VT command
      LPRINT "SPRM2";                                     'print character string
      LPRINT CHR$(11);                                     'VT command
      LPRINT "SPRM3"                                     'print character string

```

The print result of the above program is as following:

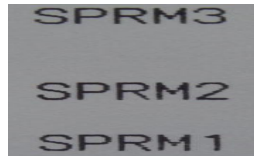

<u>VT</u>		<u>Carry out Vertical Tab Value</u>	
Format:	ASCII:	VT	
	Decimal:	11	
	Hexadecimal:	0B	

Explanation:

Feed paper to the next vertical tab position which is set by ESC B command.

Notice: if there is no vertical tab value setting, or the current position equals or is beyond the last vertical tab position, VT command is to feed paper one line only (same to LF command).

<u>ESC D</u>		<u>Set Horizontal Tab Value</u>			
Format:	ASCII:	ESC	D	n1 n2 n3...NUL	
	Decimal:	27	68	n1 n2 n3...0	
	Hexadecimal:	1B	44	n1 n2 n3...00	

Explanation:

The horizontal tab positions are entered as n1, n2 and so on, all of which should be within the line width of this model printer. Character NUL is added at the end to indicate that the command is over.

All set horizontal tab positions can be deleted by using this command in ESC D NUL format.

Example: set three horizontal tab values at 2nd, 9th line, 14th character position in one line,

ASCII:	ESC	D	STX	HT	SO	NUL
Decimal:	27	68	2	9	14	0
Hexadecimal:	1B	44	02	09	0E	00

The BASIC programs for this example are as below:

```

LPRINT "12345678901234567890123456789012" 'Ruler
LPRINT CHR$(27); CHR$(68);CHR$(2);CHR$(9);CHR$(14); CHR$(0); 'ESC D command
LPRINT CHR$(9);                               'HT command
LPRINT "HT1";                                  'print character string
LPRINT CHR$(9);                               'HT command

```

```
LPRINT "HT2";           'print character string
LPRINT CHR$(9);        'HT command
LPRINT "HT3";         'print character string
LPRINT CHR$(13);
```

The print result of the above program is as following:

```
HT1   HT2   HT3
1234567890123456789
```

<u>HT</u>		<u>Carry out Horizontal Tab Value</u>	
Format:	ASCII:	HT	
	Decimal:	9	
	Hexadecimal:	09	

Explanation:

The print position is advanced to the next horizontal tab position which is set by ESC D command.

Remark: If there is no horizontal tab value setting, or the current position equals or is beyond the last horizontal tab position, HT command won't be carried out. If the horizontal tab position is beyond the current line width, HT command won't be carried out, either.

<u>ESC f</u>		<u>Print Blank Characters or Lines</u>			
Format:	ASCII:	ESC	f	m	n
	Decimal:	27	102	m	n
	Hexadecimal:	1B	66	m	n

Explanation:

When m=0, ESC f NUL n will command to print n blank characters

When m=1, ESC f SOH n will command to print n blank lines. n=0~255.

Remark:

When m=0, if the value of n is beyond the current line width, the printer will continue to print blank in the next line.

When m=1, paper will feed n current line heights.

Example: print 6 blank characters in one line, you can send the following commands: ASCII:

```
ESC  f  NUL  ACK
Decimal:  27  102  0  6
Hexadecimal: 1B  66  00  06
```

Another example: print 6 blank lines, you can send the following commands:

```
ASCII:      ESC  f  SOH  ACK
Decimal:    27  102  01  6
Hexadecimal: 1B  66  01  06
```

<u>ESC I</u>		<u>Set Left Margin</u>		
Format:	ASCII:	ESC	I	n

Decimal:	27	108	n
Hexadecimal:	1B	6C	n

Explanation:

The value of n should be in the range from 0 to the line width of this model printer.

Default n=0, that means no left margin.

This command sets absolute position, and won't be influenced by character commands ESC U and ESC W.

Example: set left margin value to 12, you can send the following commands:

commands:

ASCII: ESC 1 ACK Decimal: 27 108 12

Hexadecimal: 1B 6C 0C

The BASIC programs for this example are as below:

LPRINT "1234567890123456" 'Ruler

LPRINT CHR\$(27); CHR\$(108); CHR\$(12); 'ESC 1 command

LPRINT "123456789012345678901234567890"

The print result is as following:

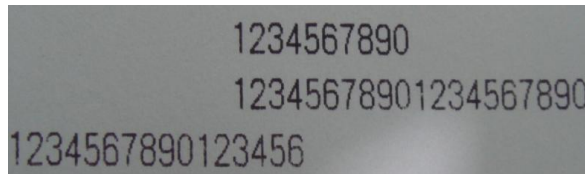

<u>ESC Q</u>	<u>Set Right Margin</u>			
Format:	ASCII:	ESC	Q	n
	Decimal:	27	81	n
	Hexadecimal:	1B	51	n

Explanation:

The value of n should be in the range from 0 to the line width of this model printer.

Default n=0, that means no right margin.

This command sets absolute position, and won't be influenced by character commands ESC U and ESC W.

After setting this command, the printer will carry out carriage return and feed line as long as the right margin position is reached.

Example: set right margin value to 12, you can send the following commands:

ASCII: ESC Q ACK

Decimal: 27 81 12

Hexadecimal: 1B 51 0C

The BASIC programs for this example are as below:

LPRINT "12345678901234567890123456789012" 'Ruler

LPRINT CHR\$(27); CHR\$(81); CHR\$(12); 'ESC Q command

LPRINT "123456789012345678901234567890";

LPRINT "12345678901234567890"

The print result is as following:

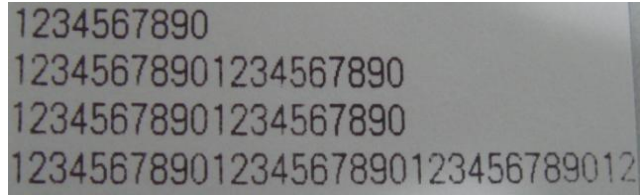

ESC P Set Character Space

Format:	ASCII:	ESC	P	n
	Decimal:	27	112	n
	Hexadecimal:	1B	70	n

Explanation:

This command is used to set space dot between characters, which is also valid for Chinese characters.

Default n=0, means no space between characters. (dot is absolute value and won't be influenced by enlarging or narrow commands), n=0~255

4.2.3 Character Setting Commands

ESC U Enlarge Width

Format:	ASCII:	ESC	U	n
	Decimal:	27	85	n
	Hexadecimal:	1B	55	n

Explanation:

After inputting this command, the characters, graphics and Chinese characters are printed at n times of normal width, n=1~8. Default n=1 when the dots are 24, while default n=2 when the dots are 16. These are normal printing width.

Remark: n=1~8, the other value of n will be invalid.

The BASIC programs for observing the enlarging effect of this command are as below:

FOR I=1 TO 3

LPRINT "CHR\$ (27); CHR\$ (85);CHR\$ (I); 'ESC U command LPRINT "SPRM"; 'Print character string NEXTI 'CR command

The print result is as following:

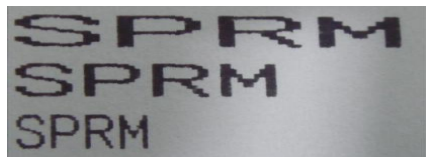

ESC V Enlarge Height

Format:	ASCII:	ESC	V	n
	Decimal:	27	86	n
	Hexadecimal:	1B	56	n

Explanation:

After inputting this command, the characters, graphics and Chinese characters are printed at n times of normal height, n=1~8. Default n=1 when the dots are 24, while default n=2 when the dots are 16. This command should be sent out at the beginning of one line.

Remark: n=1~8, the other value of n will be invalid.

The BASIC programs for observing the enlarging effect of this command are as below:

```
FOR I=1 TO 3                                ' from 1 to 3 times
LPRINT CHR$ (27); CHR$ (86); CHR$ (I);      'ESC V command
LPRINT "SPRM";                               'Print character string
NEXT I
```

The print result is as following:

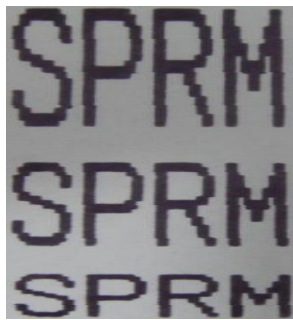

<u>ESC W</u>		<u>Enlarge Width and Height</u>		
Format:	ASCII:	ESC	W	n
	Decimal:	27	87	n
	Hexadecimal:	1B	57	n

Explanation:

After inputting this command, the characters, graphics and Chinese characters are printed at n times of normal width and height, n=1~8.

Remark: n=1~8, the other value of n will be invalid.

```
FOR I=1 TO 3                                ' from 1 to 3 times
LPRINT CHR$ (27); CHR$ (87); CHR$ (I);      'ESC W command
LPRINT "SPRM";                               'Print character string
NEXT I
```

The print result is as following:

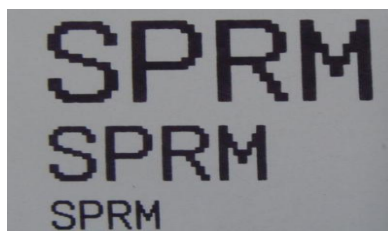

<u>ESC -</u>		<u>Select/cancel Underline Print</u>		
Format:	ASCII:	ESC	-	n

Decimal:	27	45	n
Hexadecimal:	1B	2D	n

Explanation:

When the lowest dot n=1, select underline print; when the lowest dot n=0, cancel underline print.

All characters including spaces will be printed out with underline after selecting underline print command, unless cancel the underline print command. This command is also valid for Chinese characters.

Remark: Only the lowest dot of n is valid. Default n=0.

The BASIC programs for observing the effect of this command are as below:

LPRINT CHR\$(27); CHR\$(57); CHR\$(2); ' Enlarge the width and height twice

LPRINT "SPRM";

LPRINT CHR\$(27); CHR\$(45); CHR\$(1); ' Select underline print LPRINT "SPRM"; '

SPRM print with underline LPRINT CHR\$(27); CHR\$(45); CHR\$(0); ' Cancel underline print LPRINT "SPRM";

The print result is as following:

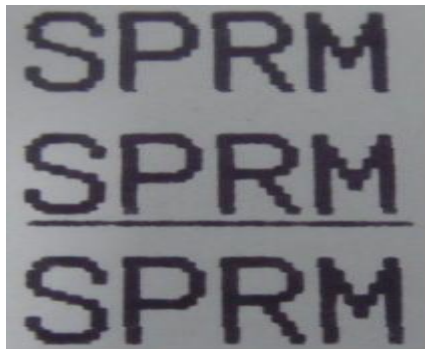

ESC +	Select/prohibit Up-line Print		
Format:	ASCII:	ESC +	n
	Decimal:	27 43	n
	Hexadecimal:	1B 2B	n

Explanation:

When the lowest dot n=1, select up-line print; when the lowest dot n=0, prohibit up-line print.

All characters including spaces will be printed out with up-line after selecting up-line print, unless prohibit the up-line print command. This command is also valid for Chinese characters.

Remark: Only the lowest dot of n is valid. Default n=0.

The BASIC programs for observing the effect of this command are as below:

LPRINT CHR\$(27); CHR\$(57); CHR\$(2); ' Enlarge the width and height twice

LPRINT "SPRM";

LPRINT CHR\$(27); CHR\$(43); CHR\$(1); ' Select up-line print LPRINT "SPRM"; '

SPRM print with up-line LPRINT CHR\$ (27); CHR\$ (43);CHR\$ (0); ' Cancel up-line print LPRINT "SPRM";

The print result is as following:

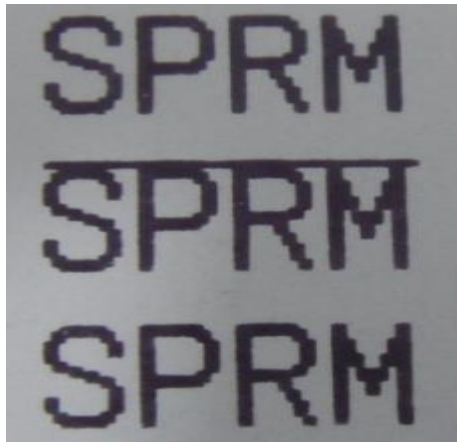

ESC i		Select/prohibit Reverse White Print		
Format:	ASCII:	ESC	i	n
	Decimal:	27	105	n
	Hexadecimal:	1B	69	n

Explanation:

When the lowest dot n=1, select reverse white print; when the lowest dot n=0, prohibit reverse white print. Reverse white print is printing in the black background, just like the film of photography. The normal printing is that printing black characters in white background. The default is prohibiting reverse white print.

Remark: Only the lowest dot of n is valid. Default n=0.

The BASIC programs are as below:

```
LPRINT CHR$ (27); CHR$ (105); CHR$ (1); ' Select reverse white print
LPRINT "SPRD"
```

The print result is as following:



ESC c		Select/prohibit Reverse Print		
Format:	ASCII:	ESC	c	n
	Decimal:	27	99	n
	Hexadecimal:	1B	63	n

Explanation:

When the lowest dot n=1, select reverse print; when the lowest dot n=0, prohibit reverse print.

Remark: Only the lowest dot of n is valid. Default n=1.

Notice: Reverse print not only supports character mode but also supports graphics mode and Chinese character mode. When print the graphics in reverse direction, pay attention to the printing sequence of graphic units, please check ESC K command.

ESC	6	Choose Characters Set 1		
Format:	ASCII:	ESC	6	
	Decimal:	27	54	
	Hexadecimal:	1B	36	

Explanation: After inputting this command, all the characters will be printed out according to the Characters Set 1 in ANK.

ESC	7	Choose Characters Set 2		
Format:	ASCII:	ESC	7	
	Decimal:	27	55	
	Hexadecimal:	1B	37	

Explanation: After inputting this command, all the characters will be printed out according to the Characters Set2 in ANK.

4.2.4 User-defined Character Setting Commands

ESC	&	User Define Character				
Format:	ASCII:	ESC	&	m	n1	n2.....n6
	Decimal:	27	38	m	n1	n2.....n6
	Hexadecimal:	1B	26	m	n1	n2.....n6

Explanation: This command permits user to define one character. Parameter m is character code the user defines, m=32~255; parameter n1, n2.....n6 is structure code to define this character. The character dots should be 6x8, which means 6column and 8dots each column. There is one character byte in each column and the MSB is on the tope as below picture,

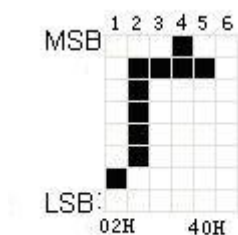

User-defined character is saved in RAM and will be lost after power off. If several ESC & commands use the same m value, only the last one is valid. At most 32 characters can be defined by users. Ref: ESC% and ESC: commands.

<u>ESC %</u>		<u>Replace User-defined Character</u>						
Format:	ASCII:	ESC %	m1	n1	m2	n2.....mk	nk	NUL
	Decimal:	27 37	m1	n1	m2	n2.....mk	nk	0
	Hexadecimal:	1B 25	m1	n1	m2	n2.....mk	nk	00

Explanation:

This command is used to replace character n in current characters set to user-defined character m. After using this command, the user-defined character m will be printed out instead of character n in current characters set.

m1,m2.....mk is user-defined character code.

n1,n2.....nk is replaced character code in current character set.

Both the value of m and n should be 32~255. Subscript k should be 1~32. The largest character number which can be replaced is 32. Character NUL is added at the end to mean the command is over. Ref: ESC % and ESC : command.

Remark: No matter in Chinese mode or character mode, replacing character will be printed when printing this character code.

<u>ESC :</u>		<u>Recover Character in Character Set</u>	
Format:	ASCII:	ESC	:
	Decimal:	27	58
	Hexadecimal:	1B	3A

Explanation:

This command is used to recover original character in character set. This character has been replaced by user-defined character through command ESC % previously. However, the used-defined character won't be deleted from RAM and still can be used through ESC % command.

The BASIC programs to observing the effect of ESC &, ESC % and ESC : commands are as below:

```

10 LPRINT CHR$(27); "W"; CHR$(8); 'Enlarge 8times from Width and Height
20 LPRINT CHR$(27); "&"; CHR$(65); 'ESC & command
30 LPRINT CHR$(&H02); CHR$(&H7C); CHR$(&H40);
40 LPRINT CHR$(&HC0); CHR$(&H40); CHR$(&H00);
50 LPRINT CHR$(27); "%"; CHR$(65); CHR$(65); CHR$(0); 'ESC % command
60 LPRINT CHR$(65); CHR$(13); 'print user-defined character
70 LPRINT CHR$(27); CHR$(58); 'ESC : command
80 LPRINT CHR$(65); 'print original character

```

The print result of the above programs is as following:



4.2.5 Graphics Printing and Codepage Choosing Commands

ESC K	Print bit-map graphics			
Format:	ASCII:	ESC		
	K	n1	n2....data.....	
Decimal:	27	75	n1 n2....data.....	
Hexadecimal:	1B	4B	n1 n2....data.....	

Explanation:

This command is used to print $(n2 \times 256 + n1) \times 8$ bit map. The width of this graphics is $(n2 \times 256 + n1)$ dots and the height is 8 dots. Each column has 8 dots and can be presented by a 8-bit byte, the MSB is on the top.

The values of $n1$, $n2$ denote a 16-bit binary data, $n1$ is LSB, $n2$ is MSB, to mean that the width of printed bitmap through ESC K command is $n2 \times 256 + n1$. In our printer series, $n2=0/1$. The sum of dots number should be ≤ 384 . Data are the bytes content of each column in this graphics. The bytes number should equal to $n2 \times 256 + n1$.

Remark: If the width of printed graphics is beyond the remaining width of current line, the beyond part of graphics won't be printed out and the printed position will change to the next line.

For example: If you want to print two Chinese characters “中文” with ESC K command, the bit- map for the two Chinese is as the below figure shows. Each character is composed by 7×8 dots to 7 columns, there is a space between the two characters, so totally there are 15 columns, then $n1=15$, $n2=0$, the 15-byte data showed in hexadecimal are as follows:

7C, 44, 44, FF, 44, 44, 7C, 00, 41, 62, 54, C8, 54, 62, 41

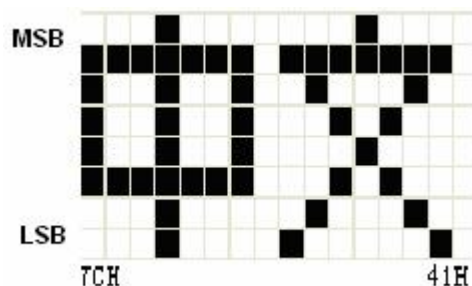

The BASIC programs for this example are as below:

```
LPRINT CHR$(27); "W"; CHR$(4); 'Enlarge the width and height 4 times
```

```
LPRINT CHR$(27); "K"; CHR$(15); CHR$(0); 'ESC K command
LPRINT CHR$(&H7C); CHR$(&H44); CHR$(&H44); CHR$(&HFF);
LPRINT CHR$(&H44); CHR$(&H44); CHR$(&H7C); CHR$(&H0);
LPRINT CHR$(&H41); CHR$(&H62); CHR$(&H54); CHR$(&HC8);
LPRINT CHR$(&H54); CHR$(&H62); CHR$(&H41);
LPRINT CHR$(10); CHR$(&H13); 'enter to print
text
```

The print result is as following:

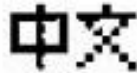

ESC ' _____	Print Curve I
Format: ASCII:	ESC ' mL mH n1L n1H n2L n2H.....n1L n1H CR
Decimal:	27 39 mL mH n1L n1H n2L n2H.....n1L n1H 13
Hexadecimal:	1B 27 mL mH n1L n1H n2L n2H.....n1L n1H

Explanation:

This command is used to print curve along the paper-feeding direction. The value of m is the number of curves to be printed, m=0~255.

There are m dots of curve in one horizontal line. n1L n1H n2L n2H.....n1L n1H presents the positions of these m curves. The numbers of n1L or n1H should equal to m. Each dot should be within the largest dots numbers of printer. The last CR ("enter") is used to print out this dot line. The whole m curves are printed out through each dot line by n1L n1H n2L n2H.....n1L n1H data.

Remark: The dot whose position is beyond the paper width won't be printed out. This command is valid no matter there is OD or not.

This instruction has the same effect as the ESC (1B 2C) instruction in the thermal mode (non-compatible dot matrix), and is a solid line (that is, automatic point compensation).

ESC , _____	Print Curve II (supplement dots automatically to be full curve)
Format: ASCII:	ESC , m n1L n1H n2L n2H.....n1L n1H CR
Decimal:	27 44 m n1L n1H n2L n2H.....n1L n1H 13
Hexadecimal:	1B 2C m n1L n1H n2L n2H.....n1L n1H OD

Explanation:

The using explanation is same as the command for Printing Curve I.

FS P _____	Print Pre-saved Bitmap
[Format] ASCII:	FS P n
Decimal:	28 80 n
Hex:	1C 50 n

Explanation:

0 ≤ n ≤ 2, this command is used to print the monochrome bitmap which is pre-saved in the Flash memory of printer. The bitmap in Flash memory can be created and wrote into printer through Setting Tool in PC. The largest width of bitmap is 384dots and the largest height is 1365dots. (The bitmap can't be over 64km.) "n" is the number of bitmap.

Remark: If the number of bitmap isn't defined, this command is invalid.

The bitmap must be monochrome.

This command won't be affected by printing mode (underline, character size or reverse white printing).

If the width of printed bitmap is beyond one line, the beyond part won't be printed out.

It needs the special setting tool to download the bitmap. Pls ref. (RMDIID Setting Tool). The downloaded bitmap through this method won't be low, unless it is covered by other bitmap.

ESC t	Choose Codepage		
Format:	ASCII:	ESC t n	
	Decimal:	27 116 n	
	Hexadecimal:	1B 74 n	

Explanation:

$0 \leq n \leq 45$, when n is $0xFE$, cancel choosing codepage. The character will be printed out according to Codepage Table in Appendix 2. Default $n=0xFE$, which means no codepage is chosen.

Choose codepage on n page from the following Codepage Table. The value of n is in decimal

format.

n	代码页	Code Page
0	CP437 [美国, 欧洲标准]	CP437 [U.S.A., Standard Europe]
1	KataKana [片假名]	Katakana
2	PC850 [多语言]	PC850 [Multilingual]
3	PC860 [葡萄牙]	PC860 [Portuguese]
4	PC863 [加拿大-法语]	PC863 [Canadian-French]
5	PC865 [北欧]	PC865 [Nordic]
6	WCP1251 [斯拉夫语]	WCP1251 [Cyrillic]
7	CP866 斯拉夫 2	CP866 Cyrilliec #2
8	MIK[斯拉夫/保加利亚]	MIK[Cyrillic /Bulgarian]
9	CP755 [东欧, 拉脱维亚 2]	CP755 [East Europe, Latvian 2]
10	[伊朗, 波斯]	Iran
11	保留	reserve
12	保留	reserve
13	保留	reserve
14	保留	reserve
15	CP862 [希伯来]	CP862 [Hebrew]
16	WCP1252 [拉丁语 1]	WCP1252 Latin I
17	WCP1253 [希腊]	WCP1253 [Greek]
18	CP852 [拉丁语 2]	CP852 [Latina 2]
19	CP858 [多种语言拉丁语 1+ 欧元符]	CP858 Multilingual Latin I +Euro)
20	伊朗 II [波斯语]	Iran II
21	拉脱维亚	Latvian
22	CP864 [阿拉伯语]	CP864 [Arabic]
23	ISO-8859-1 [西欧]	ISO-8859-1 [West Europe]
24	CP737 [希腊]	CP737 [Greek]
25	WCP1257 [波罗的海]	WCP1257 [Baltic]

26	泰文(与 TM-88 Thai character code 14 同)	Thai
27	CP720[阿拉伯语]	CP720[Arabic]
28	CP855	CP855
29	CP857[土耳其语]	CP857[Turkish]
30	WCP1250[中欧]	WCP1250[Central Eurpoe]
31	CP775	CP775
32	WCP1254[土耳其语]	WCP1254[Turkish]
33	WCP1255[希伯来语]	WCP1255[Hebrew]
34	WCP1256[阿拉伯语]	WCP1256[Arabic]
35	WCP1258[越南语]	WCP1258[Vietnam]
36	ISO-8859-2[拉丁语 2]	ISO-8859-2[Latin 2]
37	ISO-8859-3[拉丁语 3]	ISO-8859-3[Latin 3]
38	ISO-8859-4[波罗的语]	ISO-8859-4[Baltic]
39	ISO-8859-5[斯拉夫语]	ISO-8859-5[Cyrillic]
40	ISO-8859-6[阿拉伯语]	ISO-8859-6[Arabic]
41	ISO-8859-7[希腊语]	ISO-8859-7[Greek]
42	ISO-8859-8[希伯来语]	ISO-8859-8[Hebrew]
43	ISO-8859-9[土耳其语]	ISO-8859-9[Turkish]
44	ISO-8859-15[拉丁语 9]	ISO-8859-15 [Latin 3]
45	[泰文 2]	Thai2

4.2.6 Initialization Commands

<u>ESC @</u>	<u>Initialize Printer</u>
Format: ASCII: ESC @	
Decimal: 27 64	
Hexadecimal: 1B 40	

Explanation:

This command is to initialize the following contents of the printer:

- Clear the data in the print buffer;
- Restore the default;
- Delete user-defined characters.

4.2.7 Data Control Commands

<u>CR</u>	<u>Carriage Return</u>
Format: ASCII: CR	
Decimal: 13	
Hexadecimal: 0D	

Explanation:

When the "CR" command is sent to printer, all data in the print buffer will be printed out and paper will be fed one line.

<u>NUL</u>	<u>NUL</u>
------------	------------

Format:	ASCII:	NUL
	Decimal:	0
	Hexadecimal:	00

Explanation:

NUL command is used as the final code in some commands such as ESC B, ESC D, ESC% and ECS ', to denote these commands are over. NUL command is ignored when used alone.

4.2.8 Chinese Character Print Commands

The command to print Chinese character is FS standard command. All Level I&II Chinese characters and graphics, etc in 16dots&24dots Chinese character library are according to Chinese National Standard GB2312-80. For 24dots, there are only graphics, symbols, etc I A1 and A9 zone are 24dots. Each Chinese character has two bytes. Big5 characters with 16dots are in Traditional Chinese characters library.

The following is the detailed of Chinese Character Print Commands:

<u>FS &</u>		<u>Select Chinese Print Mode</u>	
Format:	ASCII:	FS	&
	Decimal:	28	38
	Hexadecimal:	1C	26

Explanation:

After printer received this command, it will switch from ASCII character print mode to Chinese character print mode. Using GB Chinese Character Library I&II.

Notice: This command is used to switch printer into Chinese Mode when printer is in normal printing mode, but won't be saved after power off. Only after setting through Setting Tool, the result can be saved.

<u>FS .</u>		<u>Cancel Chinese Print Mode</u>	
Format:	ASCII:	FS	.
	Decimal:	28	46
	Hexadecimal:	1C	2E

Explanation:

After printer received this command, it will switch from Chinese character print mode to ANK characters print mode.

Notice: This command is used to switch printer into ANK characters print mode when printer is in normal printing mode, but won't be saved after power off. Only after setting through Setting Tool, the result can be saved.

<u>FS SO</u>		<u>Set Chinese Double Width Print</u>	
Format:	ASCII:	FS	SO
	Decimal:	28	14
	Hexadecimal:	1C	0E

Explanation:

Characters following this command are printed at twice their normal width, does not enlarge the height.

Notice: this command is valid only in one line.

FS DC4 Cancel Chinese Double Width Print

Format:	ASCII:	FS	DC4
	Decimal:	28	20
	Hexadecimal:	1C	14

Explanation:

This command is to cancel FS SO command.

FS W Set the Enlarging Multiple of Chinese Character

Format:	ASCII:	FS	W	n
	Decimal:	28	87	n
	Hexadecimal:	1C	57	n

Explanation:

Characters following this command are printed at n times of their normal width and height, n=1~8

FS J Set Vertical Print

Format:	ASCII:	FS	J
	Decimal:	28	74
	Hexadecimal:	1C	4A

Explanation:

This command is to print Chinese characters vertically, which is that to print characters by rotating 90° at anticlockwise direction.

FS K Set Horizontal Print

Format:	ASCII:	FS	K
	Decimal:	28	75
	Hexadecimal:	1C	4B

Explanation:

This command is to print Chinese characters horizontally, if have not set rotation, the Chinese characters will be printed horizontally, that is normal print status.

FS I Set Chinese Character Rotational Print

Format:	ASCII:	FS	I	n
	Decimal:	28	73	n
	Hexadecimal:	1C	49	n

Explanation:

This command is to rotate Chinese characters, the values of n are as following (Default is 180°):

n	Characters rotated at anticlockwise direction
---	-----------------------------------------------

0	0°
1	90°
2	180°
3	270°
other	invalid

FS - Chinese Character with Underline Print

Format:	ASCII:	FS	-	n
	Decimal:	28	45	n
	Hexadecimal:	1C	2D	n

Explanation:

The specified Chinese characters after this command are printed with underline. When LSB n=1, underline selected; when LSB n=0, it canceled.

Remark: Only LSB of n is valid. Default n=0. This command is valid for both characters and Chinese.

FS + Chinese Character with Up-line Print

Format:	ASCII:	FS	+	n
	Decimal:	28	43	n
	Hexadecimal:	1C	2B	n

Explanation:

The specified Chinese characters after this command are printed with up-line. When LSB n=1, up-line selected; when LSB n=0, it canceled.

Remark: Only LSB of n is valid. Default n=0. This command is valid for both characters and Chinese.

ESC “ Hex Mode Print

Format:	ASCII:	ESC	“	n
	Decimal:	27	34	n
	Hexadecimal:	1B	22	n

Explanation:

When LSB n=0, cancel hex mode print; when LSB n=1, hex mode print is valid.

When in hex mode print, all the commands and data the host sent to the printer will be printed in hex codes.

Hex mode print will be carried out only when the print buffer is full.

Notice: only LSB of n is valid, default n=0

4.2.9 Real-time Commands

DLE EOT n		Real-time status transmission		
Format:	ASCII:	DLE	EOT	n
	Decimal:	16	4	n
	Hexdecimal:	10	04	n

Explanation:

Transmits the selected printer status specified by n in real-time, according to the following parameters:

- n = 1: Transmit printer status
- n = 2: Transmit off-line status
- n = 3: Transmit error status
- n = 4: Transmit paper sensor status

- The printer returns the related status at once upon receiving it.
- This command should not be used within the data sequence of another command that consists of 2 or more bytes.
- The printer transmits the current status. Each status is represented by one byte data.
- The printer transmits the status without confirming whether the host computer can receive data.
- The printer executes this command at once upon receiving it.
- This command is valid only for serial interface printer. The printer will execute this command at once after receiving it, no matter what status the printer is in.

n = 1: Printer status

Bit	0/1	HEX	Decimal	Function
0	0	0	0	Fixed to 0
1	1	2	2	Fixed to 1
2	0	0	0	Fixed to 0
3	0	0	0	On-line
	1	8	8	Off-line
4	1	10	16	Fixed to 1
5,6	-	-	-	Undefined
7	0	0	0	Fixed to 0

n=2: Off-line status

Bit	0/1	HEX	Decimal	Function
0	0	0	0	Fixed to 0
1	1	2	2	Fixed to 1
2	0	0	0	Fixed to 0
3	0	0	0	Non-pressing paper FEED button
	1	8	8	Pressing paper FEED button
4	1	10	16	Fixed to 1
5	0	0	0	Paper exists
	1	20	32	Paper lack
6	0	0	0	No error status
	1	40	64	Error status
7	0	0	0	Fixed to 0

n = 3: Error status

Bit	0/1	HEX	Decimal	Function
0	0	0	0	Fixed to 0
1	1	2	2	Fixed to 1
2	-	-	-	Undefined
3	0	0	0	Fixed to 0
4	1	10	16	Fixed to 1
5	0	0	0	Fixed to 0
6	0	0	0	Printing head with normal temperature
	1	40	64	Printing head with over-heat temperature
7	0	0	0	Fixed to 0

n=4: paper feeding status

Bit	1/0	HEX	Decimal	Function
0	0	0	0	Fixed to 0
1	1	2	2	Fixed to 1
2,3	0	0	0	Fixed to 0
4	1	10	16	Fixed to 1
5,6	0	0	0	Paper exists
	1	60	96	Paper lack
7	0	0	0	Fixed to 0

4.2.10 Bar Code Printing Commands

GS k m d1...dk NUL

Print Barcode

Format:	①ASCII:	GS	k	m	d1...dk	NUL
	Decimal:	29	107	m	d1...dk	0
	Hexadecimal:	1D	6B	m	d1...dk	00
	②ASCII:	GS	k	m	n	d1... dn
	Decimal:	29	107	m	n	d1... dn
	Hexadecimal:	1D	6B	m	n	d1... dn

Explanation:

① $0 \leq m \leq 6$ (the value range of k&d is decided by the barcode type)

② $65 \leq m \leq 73$ (the value range of k&d is decided by the barcode type)

Remark: If the width of barcode is beyond the effective printing width, no characters can be printed, but paper feeds.

m is used to choose the barcode type, showed as below:

m	Barcode type	Character number	d	
①	0	UPC-A	$11 \leq k \leq 12$	$48 \leq d \leq 57$
	1	UPC-E	$11 \leq k \leq 12$	$48 \leq d \leq 57$
	2	JAN13 (EAN13)	$12 \leq k \leq 13$	$48 \leq d \leq 57$
	3	JAN 8 (EAN8)	$7 \leq k \leq 8$	$48 \leq d \leq 57$
	4	CODE39	$1 \leq k \leq 255$	$45 \leq d \leq 57, 65 \leq d \leq 90, 32, 36, 37, 43$
	5	ITF	$1 \leq k \leq 255$	$48 \leq d \leq 57$
	6	CODABAR	$1 \leq k \leq 255$	$48 \leq d \leq 57, 65 \leq d \leq 68, 36, 43, 45, 46, 47, 58$
②	65	UPC-A	$11 \leq n \leq 12$	$48 \leq d \leq 57$
	66	UPC-E	$11 \leq n \leq 12$	$48 \leq d \leq 57$
	67	JAN13 (EAN13)	$12 \leq n \leq 13$	$48 \leq d \leq 57$
	68	JAN 8 (EAN8)	$7 \leq n \leq 8$	$48 \leq d \leq 57$

69	CODE39	$1 \leq n \leq 255$	$45 \leq d \leq 57, 65 \leq d \leq 90, 32, 36, 37, 43$ $d1 = dk = 42$
70	ITF	$1 \leq n \leq 255$	$48 \leq d \leq 57$
71	CODABAR	$1 \leq n \leq 255$	$48 \leq d \leq 57, 65 \leq d \leq 68, 36, 43, 45, 46, 47, 58$
72	CODE93	$1 \leq n \leq 255$	$0 \leq d \leq 127$
73	CODE128	$2 \leq n \leq 255$	$0 \leq d \leq 127$

Explanation for command ①:

Character NUL is added at the last to mean that this command is over.

When UPC-A or UPC-E is choosed, after 12bytes barcode data is received, the other characters will be managed as the common characters.

When JAN13 (EAN13) is choosed, after 13bytes barcode data is received, the other characters will be managed as the common characters.

When JAN8 (EAN8) is choosed, after 8bytes barcode data is received, the other characters will be deal with as the common characters.

The numbers of ITF code data must be even number. If odd numbers of barcode data is input, the last one will be ignored.

Explanation for command ②:

n is used to denote the number of barcode data. Printer will deal with the last n bytes data as the barcode data.

If n is beyond the specified range, the printer will not deal with this command and just deal with the data as the common data.

Explanation:

- If barcode data d is beyond the specified range, this command is invalid.
- If the barcode is beyond printing zone at horizontal direction, invalid.
- No matter how much the line height is set by command ESC 1 n, paper feeding length will be same with the barcode height.
- This command is valid only that there is no data in the printing buffer. If there is data in printing buffer, this command will be ignored.
- After printing barcode, the printing position will be set on the first line.
- This command won't be affected by Print Mode Setting (such as bold printing, duplicate printing, underline, character size, reverse white printing, etc), but will be affected by Invert Printing.

When CODE93 (m = 72) is choose:

When printer print HRI character, (■+one alphabet character) is used as one control character (<00>H to <1F>H and <7F>H).

Conversion form between control character and HRI character is as below,

Control character			HRI character	Control character			HRI character
ASCII	Hex	Decimal		ASCII	Hex	Decimal	
NUL	00	0	■ U	DLE	10	16	■ P
SOH	01	1	■ A	DC1	11	17	■ Q
STX	02	2	■ B	DC2	12	18	■ R
ETX	03	3	■ C	DC3	13	19	■ S
EOT	04	4	■ D	DC4	14	20	■ T
ENQ	05	5	■ E	NAK	15	21	■ U
ACK	06	6	■ F	SYN	16	22	■ V
BEL	07	7	■ G	ETB	17	23	■ W
BS	08	8	■ H	CAN	18	24	■ X
HT	09	9	■ I	EM	19	25	■ Y
LF	0A	10	■ J	SUB	1A	26	■ Z
VT	0B	11	■ K	ESC	1B	27	■ A
FF	0C	12	■ L	FS	1C	28	■ B
CR	0D	13	■ M	GS	1D	29	■ C
SO	0E	14	■ N	RS	1E	30	■ D
SI	0F	15	■ O	US	1F	31	■ E
				DEL	7F	127	■ T

When CODE128 (m = 73) is choose:

· Pls refer to Appendix 5 – Related information and characters set of CODE128.

· When CODE128 is used, pls encode according to the below structions:

1. Do choose characters set (one of CODE A, CODE B and CODE C) before the barcode data.

2. Choosing characters set is finished through sending character “{” to combine with the other character; ASCII character “{” is finished by sending character “{” twice.

Specified Characters Set	Sending Data		
	ASCII	Hex	Decimal
SHIFT	{S	7B, 53	123,83
CODE A	{A	7B, 41	123, 65

CODE B	{B	7B, 42	123, 66
CODE C	{C	7B, 43	123, 67
FNC1	{1	7B, 31	123, 49
FNC2	{2	7B, 32	123, 50
FNC3	{3	7B, 33	123, 51
FNC4	{4	7B, 34	123, 52
"{"	{{	7B, 7B	123, 123

[Example] : Printing "No. 123456"

In this example, printer will print "No." by CODE B, and print the other numbers by CODE C:

GS k 73 10 123 66 78 111 46 123 67 12 34 56



- If it is not the choosing of characters set at the beginning of barcode data, the printer will stop dealing with this command and deal with the other data as the common data.
- If the combination by "{" and that following character is not in the above form, the printer will stop dealing with this command and deal with the other data as the common data.
- If the character received by printer is not barcode characters set data, the printer will stop dealing with this command and deal with the other data as the common data.
- When printer prints HRI characters, it doesn't print shift character and choosing data in characters set.
- Function characters in HRI character won't be printed.
- Control characters(<00>H to <1F>H and <7F>H)in HRI character won't be printed.

Pls be sure the space at both left and right side of barcode. The space will be different according to the different barcode.

Pls refer to GS H, GS h, GS w, Appendix 5.

GS H n Choose printing position of HRI character

Format:	ASCII:	GS	H	n
	Decimal:	29	72	n
	Hexadecimal:	1D	48	n

Explanation: $0 \leq n \leq 3$, $48 \leq n \leq 51$. When printing barcode, choosing printing position for HRI characters.

n can appoint the printing position of HRI:

n	Printing position
0, 48	Don't print
1, 49	Above barcode
2, 50	Below barcode
3, 51	Both above and below barcode

HRI is note character for barcode content. Default value: n=0.

Pls refer to GS k

Remark: if n is in other value, it is invalid.

GS h n Set Barcode Height

Format:	ASCII:	GS	h	n
	Decimal:	29	104	n
	Hexadecimal:	1D	68	n

Explanation: Set the height of printed barcode. n=0~255, unit is dot. If n=0, it is 256dots.

Default value n=60.

GS w n Set Barcode Width

Format :	ASCII :	GS	w	n
	Decimal:	29	119	n
	Hexadecimal:	1D	77	n

Explanation: $2 \leq n \leq 6$ (the other value of n is invalid). Set the horizontal module width of barcode. The detail is as below,

n	Width of single basic module (mm)	Width of double basic module	
		Narrow basic module (mm)	Wide basic module(mm)
2	0.25	0.25	0.625
3	0.375	0.375	0.875
4	0.5	0.5	1.25
5	0.625	0.625	1.625
6	0.75	0.75	1.875

Single basic module barcode: UPC-A, UPC-E, JAN13 (EAN13), JAN8 (EAN8), CODE93,

CODE128

Double basic module barcode: CODE39, ITF, CODABAR

Default value: n = 3. Pls refer to GS k.

Chapter 5 Using and Maintenance

5.1 Printing Head Maintenance

In order to guarantee the normal work of the printer, pls notice that do not disassemble the printing head. If the outer case of printer is not used, pls pay more attention to protect the printing head.

1. If you do not use the printer for a long time, please don't put through the printer on the power.
2. If the printer works abnormally, please turn off the printer power.
3. The used power must meet the requirements, otherwise it will be disadvantageous for the print head.
4. While changing the paper roll, please notice whether there is paper scrap on the print head. If so, please blow gently.
5. Keep the circuit board of the printer clean and dustless.
6. When the thermal printer can't print clearly, the printing head can be wiped by alcohol cotton ball.

5.2 Other

Please also notice the following aspects:

1. Don't insert and pull out the chip. If there is abnormality, please hand over to the producer for repairing.
2. When you suppress to join the electric wire by yourself, pls do pay attention to the interface of printer - parallel interface or serial interface, to avoid the wrong connection with the host computer.

Chapter 6 Printer Using under Windows

The version of SP-RMD8 printers' driver software is SP-DRV211. The manual for driver software and installation can be downloaded from our website. Do not introduce the details here.

Remark: During installing driver, choose the printer model "58 thermal series". The other details can be checked from Installation Manual.

Appendix 1 Valid Codes Form under ANK printing

The serial numbers of valid codes are from 00H to 0FFH under ANK printing, among which 00H-1FH are control codes and 20H-0FFH are character codes. Character codes are composed by two characters sets. The character codes of each character set are all in 20H-0FFH permutation.

Characters Set 1:

	0	1	2	3	4	5	6	7	8	9	A	B	C	D	E	F
2		!	"	#	\$	%	&	'	()	*	+	,	-	.	/
3	0	1	2	3	4	5	6	7	8	9	:	;	<	=	>	?
4	@	A	B	C	D	E	F	G	H	I	J	K	L	M	N	O
5	P	Q	R	S	T	U	V	W	X	Y	Z	[\]	†	—
6	ˆ	a	b	c	d	e	f	g	h	i	j	k	l	m	n	o
7	p	q	r	s	t	u	v	w	x	y	z	{		}	~	
8	0	一	二	三	四	五	六	七	八	九	十	元	年	月	日	¥
9	£	§	↓	→	∧	±	÷	∞	□	...	o	□	²	³	₂	₃
A	α	β	γ	δ	ε	ζ	η	θ	λ	μ	ν	Ω	ξ	π	ρ	σ
B	τ	Φ	Ψ	ω	Γ	∆	Π	Σ	Ψ	Ω	Ξ	Θ	Λ	Φ	Υ	∠
C	[=	□]	ˉ	-			/	\	┌	└	┐	┑	□	×
D	[=	□]	ˉ	-			/	\	┌	└	┐	┑	┒	┓
E	└	┐	┌	┑	┒	┓	└	┐	┌	┑	┒	┓	└	┐	┌	┑
F	▪	▪	▪	▪	▪	▪	▪	▪	▪	▪	▪	▪	▪	▪	▪	+

Characters Set 2:

	0	1	2	3	4	5	6	7	8	9	A	B	C	D	E	F
2	百	千	万	Π	℃	℉	⁻¹	4	₄	½	⅓	¼	∓	×	√	⊥
3	//	∥	∩	∪	⊗	⊂	⊃	≡	≠	∇	∇	∂	∫	∫	∅	∴
4	∴	=	≅	≈	≠	∞	≤	≥	≪	≫	♠	♠	♠	♠	♠	∴
5	※	□	()	《 》	『 』	【 】	~	..	○	♥	♦	♣				
6	♠	ア	イ	ウ	エ	オ	カ	キ	ク	ケ	コ	サ	シ	ス	セ	ソ
7	タ	チ	ツ	テ	ト	ナ	ニ	ス	ネ	ノ	ハ	ヒ	フ	ヘ	ホ	マ
8	ミ	ム	メ	モ	ル	レ	ロ	ワ	ヰ	ヱ	ヲ	ヰ	ヱ	ヲ		
9	ン	ァ	ゥ	ェ	ォ	ャ	ュ	ヱ	ヰ	〇	Б	Д	Е	Ж	З	
A	И	Й	Л	Ц	Ч	Ш	Щ	Ъ	Ы	Э	Ю	Я	б	с	е	о
B	ø	g	u	é	á	ã	ä	ã	ä	ä	S	e	ë	è	ï	ï
C	Ä	É	æ	Æ	Ô	Ö	Û	Ü	ÿ	Ö	Ü	ƒ	ƒ	ó		
D	i	ó	ù	ñ	Ñ	ä	ö	ü	ÿ	ä	ä	ä	ä	ä	S	
E	é	ë	è	ï	ï	ï	Ä	Ä	É	æ	Æ	Ô	Ö	Û	Ü	
F	ÿ	Ö	Ü	ƒ	ƒ	ó	i	ó	ù	ñ	Ñ	ä	ö	ü	n	

Appendix 2 Valid Codes Form under Chinese printing

The serial numbers of valid codes are from 00H to 0FFH under Chinese printing, among which 00H-1FH are control codes and 20H-0FFH are character codes.

HEX	0	1	2	3	4	5	6	7	8	9	A	B	C	D	E	F
2		!	”	#	\$	%	&	'	()	*	+	,	-	.	/	
3	0	1	2	3	4	5	6	7	8	9	:	:	<	=	>	?
4	@	A	B	C	D	E	F	G	H	I	J	K	L	M	N	O
5	P	Q	R	S	T	U	V	W	X	Y	Z	[\]	^	_
6	`	a	b	c	d	e	f	g	h	i	j	k	l	m	n	o
7	p	q	r	s	t	u	v	w	x	y	z	{		}	~	
8	€	ü	é	â	ä	à	å	ç	ê	ë	è	ï	î	ì	Ä	Å
9	É	Æ	FE	ô	ö	ò	û	ù	ÿ	Ö	Ü	¢	£	¥	ℜ	f
A	á	í	ó	ú	ñ	Ñ	ª	º	¿	Γ	γ	½	¼	ı	《	》
B	☐	☐	☐		†	‡	‡	π	π	‡	‡	π	π	π	π	π
C	L	⊥	⊥	†	—	†	‡	‡	ℒ	ℒ	⊥	⊥	‡	=	‡	⊥
D	⊥	⊥	π	ℒ	ℒ	F	π	‡	‡	J	Γ	■	■	■	■	■
E	α	β	Γ	π	Σ	σ	μ	τ	Φ	θ	Ω	δ	∞	φ	∈	∩
F	≡	±	≥	≤	[]	÷	≈	◦	•	-	√	n	2	■	

Appendix 3 Printing Commands Form

Decimal	Hexadecimal	Symbol&Format	Function	Page
0	0	NUL	Ending Mark	30
10	0A	LF	FEED LINE	15
13	0D	CR	Carriage Return	29
16 4 n	10 04 n	DLE EOT n	Real-time status transmission	33
27 34 n	1B 22 n	ESC " n	Hex Mode Print	32
27 37 n	1B 25 n	ESC % m1 n1.....mk nk 00	Replace User-defined Character	25
27 38	1B 26	ESC & m n1 n2.....n6	User Define Character	24
27 39	1B 27	ESC' m ...nL nIH CR	Print M Curve dots (dashed)	27
27 43 n	1B 2B n	ESC + n	Select/prohibit Up-line Print	22
27 44	1B 2C	ESC , m...nL nIH CR	Print M Curve dots (full line)	27
27 45 n	1B 2D n	ESC - n	Select/cancel Underline Print	21
27 49 n	1B 31 n	ESC 1 n	Set n Dot-line Spacing	16
27 54	1B 36	ESC 6	Choose Characters Set 1	24
27 55	1B 37	ESC 7	Choose Characters Set 2	24
27 58	1B 3A	ESC :	Recover Character in Character Set	25
27 64	1B 40	ESC @	Initialize Printer	29
27 66	1B 42	ESC B n1...nkNUL	Set Vertical Tab Value	16
27 68	1B 44	ESC D n1...nk NUL	Set Horizontal Tab Value	17
27 74 n	1B 4A n	ESC J n	n Dot Line Feed	15
27 75	1B 4B	ESC K n1...n2...data	Print bit-map graphics	26
27 81 n	1B 51 n	ESC Q n	Set Right Margin	19
27 85 n	1B 55 n	ESC U n	Enlarge Width	20

27 86 n	1B 56 n	ESC V n	Enlarge Height	20
27 87 n	1B 57 n	ESC W n	Enlarge Width and Height	21
27 99 n	1B 63 n	ESC C n	Select/prohibit Reverse Print	23
27 102 m n	1B 66 m n	ESC f m n	Print Blank Characters or Lines	18
27 105 n	1B 69 n	ESC i n	Select/prohibit Reverse White Print	23
27 108 n	1B 6C n	ESC l n	Set Left Margin	19
27 112 n	1B 70 n	ESC P n	Set Character Space	20
27 116 n	1B 74 n	ESC t n	Choose Codepage	28
28 14 n	1C 0E n	FS SO n	Set Chinese Double Width Print	31
28 20	1C 14	FS DC 4	Cancel Chinese Double Width Print	31
28 38	1C 26	FS &	Select Chinese Print Mode	30
28 43 n	1C 2B n	FS + n	Chinese Character with Up-line Print	32
28 45 n	1C 2D n	FS - n	Chinese Character with Underline Print	32
28 46	1C 2E	FS ·	Cancel Chinese Print Mode	30
28 73 n	1C 49 n	FS l n	Set Chinese Character Rotational Print	31
28 74	1C 4A	FS J	Set Vertical Print	31
28 75	1C 4B	FS K	Set Horizontal Print	31
28 80 n	1C 50 n	FS P n	Print Pre-saved Bitmap	27
28 87 n	1C 57 n	FS W n	Set the Enlarging Multiple of Chinese Character	31
29 72 n	1D 48 n	GS H n	Choose printing position of HRI character	38
29 104 n	1D 68 n	GS h n	Set Barcode Height	39
29 107 n	1D 6B n	GS k n	Print Barcode	34
29 119 n	1D 77 n	GS w n	Set Barcode Width	39
Note: When using the setting tool to set English characters, the font will automatically change to 8 * 6. If you need, please choose 8 * 16.				

Appendix 4 Example of MCU Interface

Recommended hardware diagram of host computer:

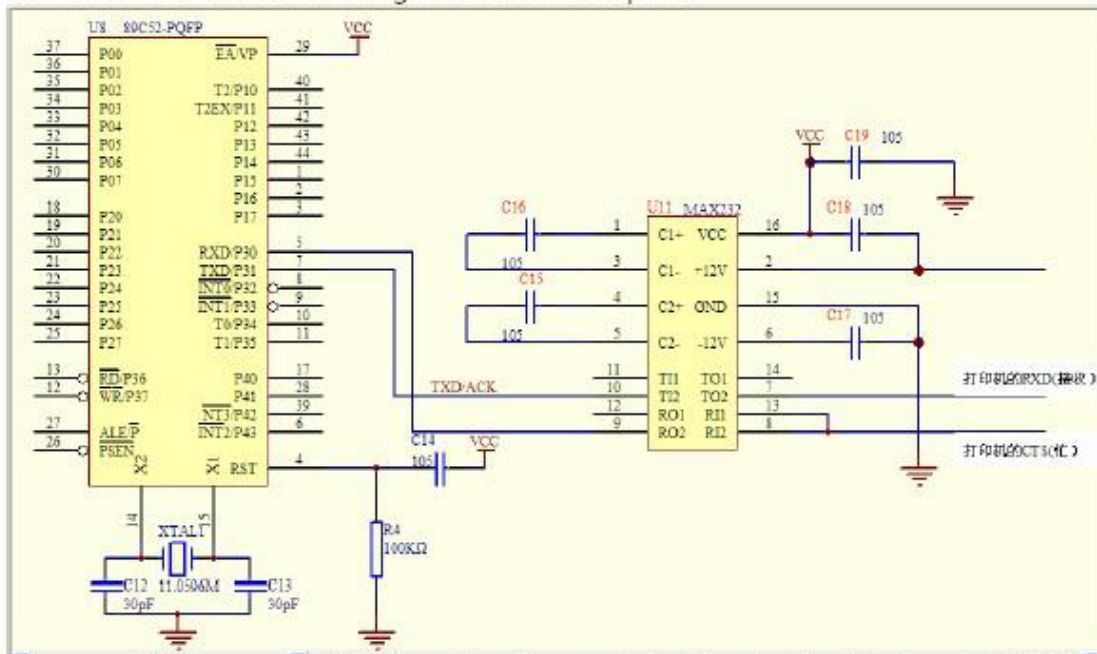

Recommended It is recommended that the serial port be connected to three wires, the printer's receive (RXD), the printer's busy (CTS), and the power supply (GND).

See the description of the printer's serial interface in 3.1.1



PIN Assignment of serial port

PIN Assignment of serial port

PIN	Name	Source	Explanation
2	RXD	Host	Printer receives data from host
3	TXD	Printer	Printer send control code X-ON/X-OFF and data to host
5	CTS	Printer	When the signal is "MARK", printer is busy could not receive data; When it is "SPACE", printer is ready to receive data.
6	DSR	Printer	The signal is "SPACE", printer is online
7	GND	—	Signal ground
8	DCD	Printer	Same to CTS

Assembly program is like below:

```

cts      bit    p3.0      ;
ORG 0000H
Strat:  mov    tmod,#20h  ; Initialization COM
        mov    tl1,#0fdh
        mov    th1,#0fdh  ; Baud rate 9600
        mov    scon,#0c0h ; Mode 3
        setb  tr1
main:   mov    r7,#0
        mov    dptr,#date
loop:   mov    a,r7
        movc  a,@a+dptr   ; Access
        inc   r7
        cjne  a,#00h,loop1 ; Finish sign 00H
        sjmp  $
loop1:  call  sczj
        sjmp  loop
sczj:   jb    cts,$       ; Busy
        mov  c,psw.0
        ;
        ;cpl c           ; Odd parity, C revers
        mov  tb8,c       ; Even parity
        mov  sbuf,a
        jnb  ti,$        ; Wait sending finished
        clr  ti
        ret
date:   db  1bh,40h
        db  'sprinter rs232 test'
        db  0dh,00h
        ret
        end

```

C program is like below:

```

#include <reg52.h>
unsigned char  inbuf1[19]="sprinter rs232 test";
sbit busy = P3^0;
void send_char_com(unsigned char ch) //Send a bite to COM
{while(busy); // Busy
//TB8=P; // Even parity
TB8=!P; // Odd parity
SBUF=ch;
while(TI==0); // Wait sending finished
TI=0;
}
void send_string_com(unsigned char *str) // Send string
through serial
port
{
unsigned int k=0;
do
{
send_char_com(*(str+k));
k++;
}while(k<19);
}
main()
{
SCON=0xc0; // Mode 3
TMOD=0x20; //
TH1=0xfd; // Baud rate 9600
TR1=1;
send_char_com (0x1b);
send_char_com (0x40); //Initialization command
send_string_com(inbuf1); of printer
send_char_com (0x0a);}

```

When the data is not big, CTS can not be connected.

Host parallel I/O mode recommended Schematic

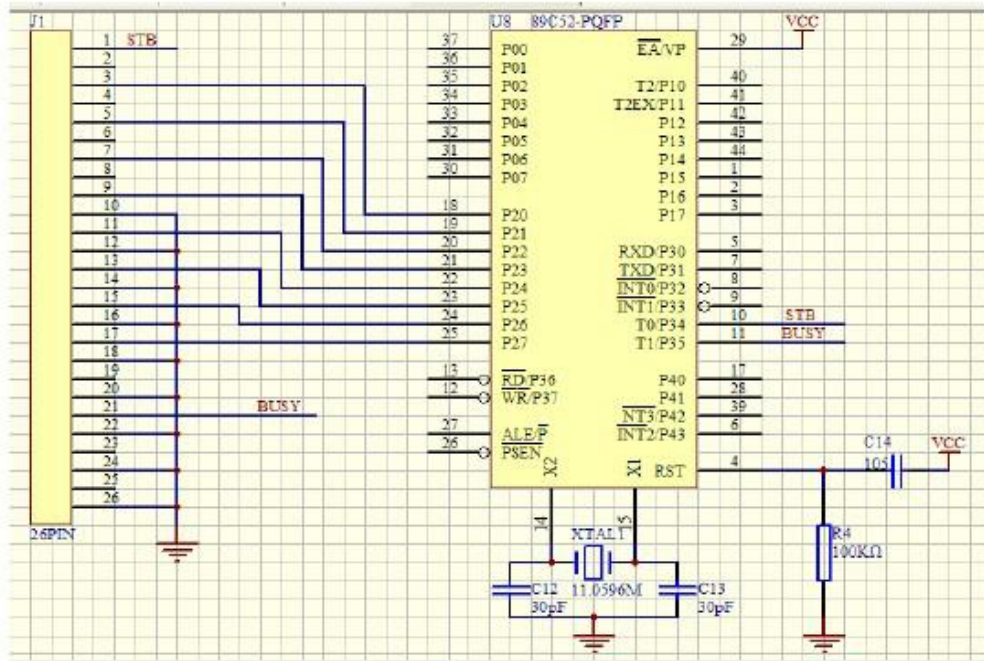

The definition of the printer's parallel interface is shown in Figure 3.1.2.

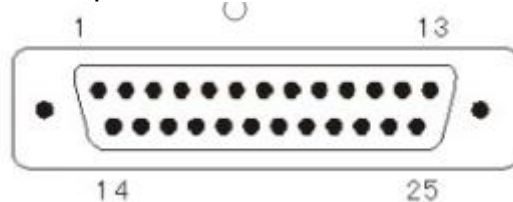

DB25 Parallel interface connector PIN assignment

The pin assignment of parallel interface is shown as table 2-2:

Pin No.	Signal	Direction	Description
1	/STB	In	Strobe pulse to latch data, reading occurs at raising edge.
2	DATA1	In	These signals represent the 1st bit to 8th bit of the parallel interface data, each signal is at HIGHT level when data is logic 1, and LOW when data is logic 0.
3	DATA2	In	
4	DATA3	In	
5	DATA4	In	
6	DATA5	In	
7	DATA6	In	
8	DATA7	In	
9	DATA8	In	
10	/ACK	Out	Answer pulse, LOW level signal indicates that data have already been received and the printer gets ready to receive the next data.

11	BUSY	Out	HIGH level signal indicates that the printer is BUSY and can not receive data.
12	PE	Out	HIGH level signal indicates that paper is end.
13	SEL	Out	Pulling up to HIGH level signal by a resistor indicates the printer is online.
15	/ERR	Out	Pulling up to HIGH level signal by a resistor indicates there is no error.
14,16,17	NC	---	No connection
19-25	GND	---	Grounding logical 0 level

Note: (1) "In" denotes inputting to the printer, "Out" denotes outputting from the printer.

(2) Signal level is TTL standard.

Fig. Pin Assignment of Parallel Interface

DB36 Parallel interface connector PIN assignment

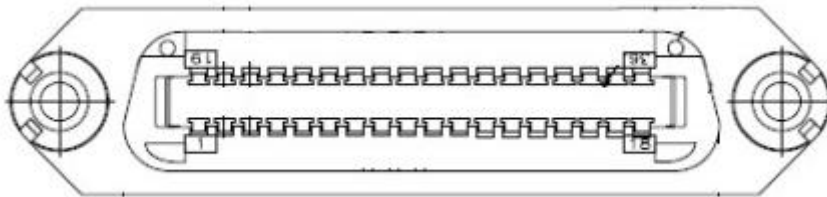

DB-36 Parallel PIN assignment:

Pin No.	Signal	Direction	Description
1	/STB	In	Strobe pulse to latch data, reading occurs at raising edge.
2	DATA1	In	These signals represent the 1st bit to 8th bit of the parallel interface data, each signal is at HIGHT level when data is logic 1, and LOW when data is logic 0.
3	DATA2	In	
4	DATA3	In	
5	DATA4	In	
6	DATA5	In	
7	DATA6	In	
8	DATA7	In	
9	DATA8	In	
10	/ACK	Out	Answer pulse, LOW level signal indicates that data have already been received and the printer gets ready to receive the next data.
11	BUSY	Out	HIGH level signal indicates that the printer is BUSY and can not receive data.

12	PE	Out	HIGH level signal indicates that paper is end.
13	SEL	Out	Pulling up to HIGH level signal by a resistor indicates the printer is online.
32	/ERR	Out	Pulling up to HIGH level signal by a resistor indicates there is no error.
14,15,16,17,18,34,36	NC	---	No connection
16,19-30,33	GND	---	Grounding logical 0 level

Assembly program as below:

```

STB      bit    p3.4
BUSY     BIT    P3.5
PDATA    BIT    P2
                ORG 0000H

strat:
LOOP:MOV DPTR,#DATE
LOOP1:CLR A
        MOVC A,@A+DPTR
        CJNE A,#00H,GO1 ; Printer end mark
        SJMP LOOP
GO1:LCALL PRINT
        INC DPTR
        SJMP $
PRINT:PUSH DPH
        PUSH DPL
        JB  BUSY,$ ; Busy
        MOV P2,A
        CLR STB ; Send STB rising edge
        NOP
        NOP
        NOP
        SETB STB
        NOP
        NOP
        NOP
        NOP
        POP DPL
        POP DPH
        RET
date: db 1bh,40h
      db 'sprinter test ok'
      db 0dh,00h
      ret

```

C program as below:

```

#include <reg52.h>
#include <intrins.h>
unsigned char inbuf1[16]="sprinter test ok";
sbit busy = P3^5;
sbit STB=P3^4;
#define P_DATA P2
void send_char_P(unsigned char ch)// Send a character to
{                                     parallel
while(busy); // Busy
P2=ch;
STB=0; //STB rising edge
_nop_0; //Adjust STB pulse
_nop_0;
_nop_0;
_nop_0;
STB=1;
_nop_0;
_nop_0;
_nop_0;
_nop_0;
}
void send_string_P(unsigned char *str) //Serial interface
{                                     sends characters
unsigned int k=0;
do
{
send_char_P(*(str+k));
k++;
}while(k<16);
}
main()
{
send_char_P(0x1b);
send_char_P(0x40);
send_string_P(inbuf1);
send_char_P(0x0a);
}

```

Recommended schematic diagram of the parallel port bus mode of the host computer

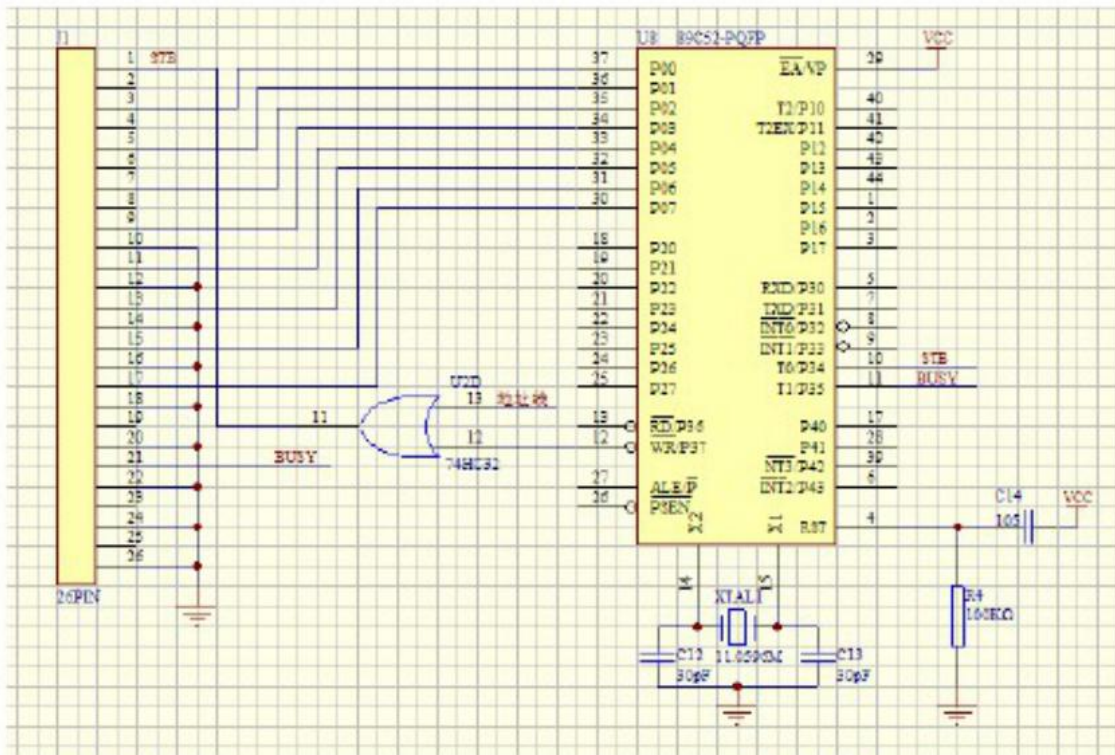

Assemble program as below:

```

        wrdata EQU **H ; Printer Address
        BUSY BIT P1.0
        ORG 0000H
strat:  mov r7,#0
        mov dptr,#date
loop:   mov a,r7
        movc a,@a+dptr
        inc r7
        cjne a,#00h,loop1
        sjmp strat ;Send circularly
loop1:  call PRINT
        sjmp loop
PRINT:  PUSH DPH
        PUSH DPL
        JB BUSY, $ ; Busy
        MOV DPTR,#wrdata
        MOVX @DPTR,A
        POP DPL
        POP DPH
        RET

```

C program as below:

```

#include <reg52.h>
#include <intrins.h>
unsigned char inbuf1[16]="sprinter test ok";
sbit busy = P1^0;
unsigned char xdata wrchar_at_0x** // ** Defining an absolute add.
void send_char(unsigned char ch) // Parallel sends a
{
    byte
    while(busy); // Busy
    wrchar=ch;
}
void send_string_P(unsigned char *str) // Parallel sends
{
    characters
    unsigned int k=0;
    do
    {
        send_char(*(str+k));
        k++;
    }while(k<16);
}
main()

```