

# SPRT®

## Thermal Printer User Manual (SP-RMD17)

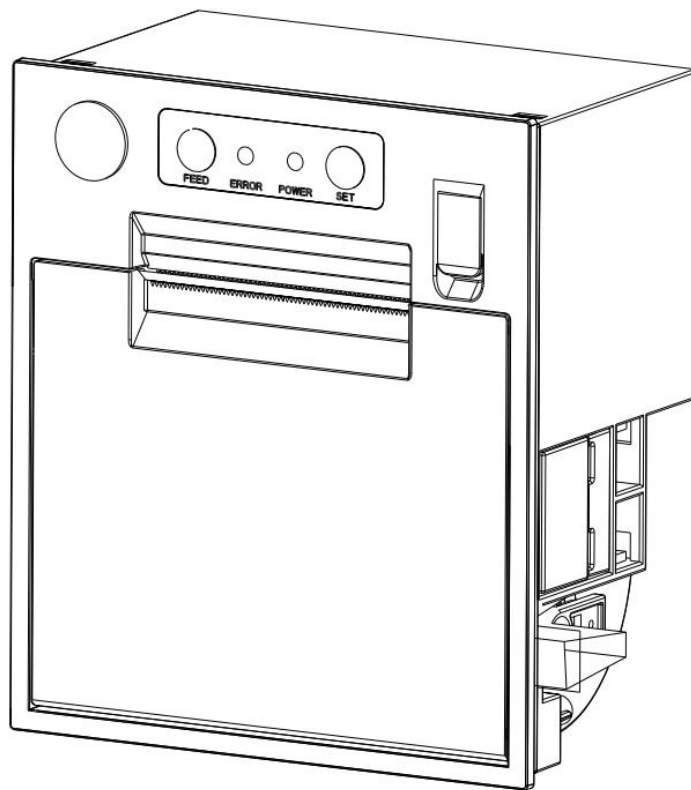

**(Ver 1.05)**

**Beijing Spirit Technology Development Co.,Ltd.**

**[www.sprt-printer.com](http://www.sprt-printer.com)**

# CONTENT

Introduction .....	1
Chapter 1 Feature and Performance .....	1
1.1 Print Performance .....	1
1.2 Print Paper .....	1
1.5 Print Control Commands .....	2
1.6 Power Supply .....	2
1.7 Operation Environment .....	2
1.8 Outline Dimension and installation size .....	2
Chapter 2 Operation Specification .....	3
2.1 Printer Appearance .....	3
2.2 Installation of the printer .....	6
2.3 Paper Installation .....	6
2.3.1 Paper Loading .....	6
2.4 Interface .....	7
2.4.1 Serial Interface .....	7
2.4.2 USB interface .....	8
2.4.3 Power Connection .....	9
2.4.4 Parallel interface connection .....	9
2.4.5 Bluetooth Connection .....	10
2.4.6 Cash Drawer Interface .....	11
2.5 Indicators, Buzzer and Buttons Operation .....	11
2.6 Power on the printer .....	12
2.7 Self test .....	13
2.8 Hexadecimal Printing .....	13
2.9 Printer Parameter Setting .....	13
2.10 Entering program upgrading mode .....	13
Appendix A: Parameter Setting .....	14

# Introduction

RMD17 printer is a new type line thermal printer, which features in fast speed print, low print noise, high reliability, perfect print quality and ribbon needless, avoiding the vexation of regular maintenance.

## Chapter 1 Feature and Performance

### 1.1 Print Performance

- Print method: direct thermal
- Print paper width: 57.5±0.5mm
- Print density: 8 dots/mm, 384 dots/line
- Print speed: max 70mm / sec.
- Reliability

(1)Print head life: 60km

Using condition:

- \* Print 12 × 24 ANK characters, print 50 lines each time, intermittent print repeatedly
- \* Printing density of every dot line cannot be over 25%, repeat printing cannot exceed over 11 times on same dot of every character line.
- \* Use specified thermal paper
- Valid print width: 48mm

### 1.2 Print Paper

- Thermal paper roll model: TF50KS—E(Japan paper co.ltd)  
AF50KS-E (JUJO THERMAL)
- Thermal paper roll: Width — — — 57.5±0.5mm  
Outer Diameter — — — 60mm(max.)  
Inner Diameter — — — 13mm±0.3(min.)  
Thickness — — — 0.06mm~0.08mm

### 1.3 Print Font

- ANK Character Set  
12×24 dots, 1.5(W)×3.00(H)mm
- GB18030(Chinese):  
24×24 dots, 3.00(W)×3.00(H)mm.

## 1.4 Interface

- RS-232C Serial Interface:  
IDC10 socket, supports XON/XOFF and DTR/DSR protocols.  
Baud rate:1200, 2400, 4800, 9600, 19200, 38400, 57600, 115200bps adjustable.  
Data structure: 1 start bit + (7 or 8) data bits + 1 stop bit.  
Parity checking: no parity or odd, even parity optional.
- USB Interface:  
PH4 interface
- Parallel Interface:  
IDC26 pin socket.
- Cash drawer control  
DC12V, 1A, 6 cable RJ-11 socket.(support 24V cash drawer)

## 1.5 Print Control Commands

- Character print commands: support ANK characters, user-defined characters and double-width, double height print of Chinese characters, the character line spacing is adjustable.
- Graphics print commands: support the print of bit-map graphics and download bit-map graphics with different density
- GS bar code print commands: Support print UPC-A, UPC-E, EAN-13, EAN-8, CODE39, ITF25, CODABAR, CODE93, CODE128 barcode

## 1.6 Power Supply

- DC12V±10%, 2A, 2114s-02 power socket.

## 1.7 Operation Environment

- Operation temperature: 0~50°C; Operation humidity: 10~80%
- Storage temperature: -20~60°C; Storage humidity: 10~90%

## 1.8 Outline Dimension and installation size

Installation size: 111.5mm×128.5mm (W×H)      depth:77mm

Outline dimension: 132mm×115mm×79.5mm (W×H×D)

Please find outer dimension in pic.1-1:

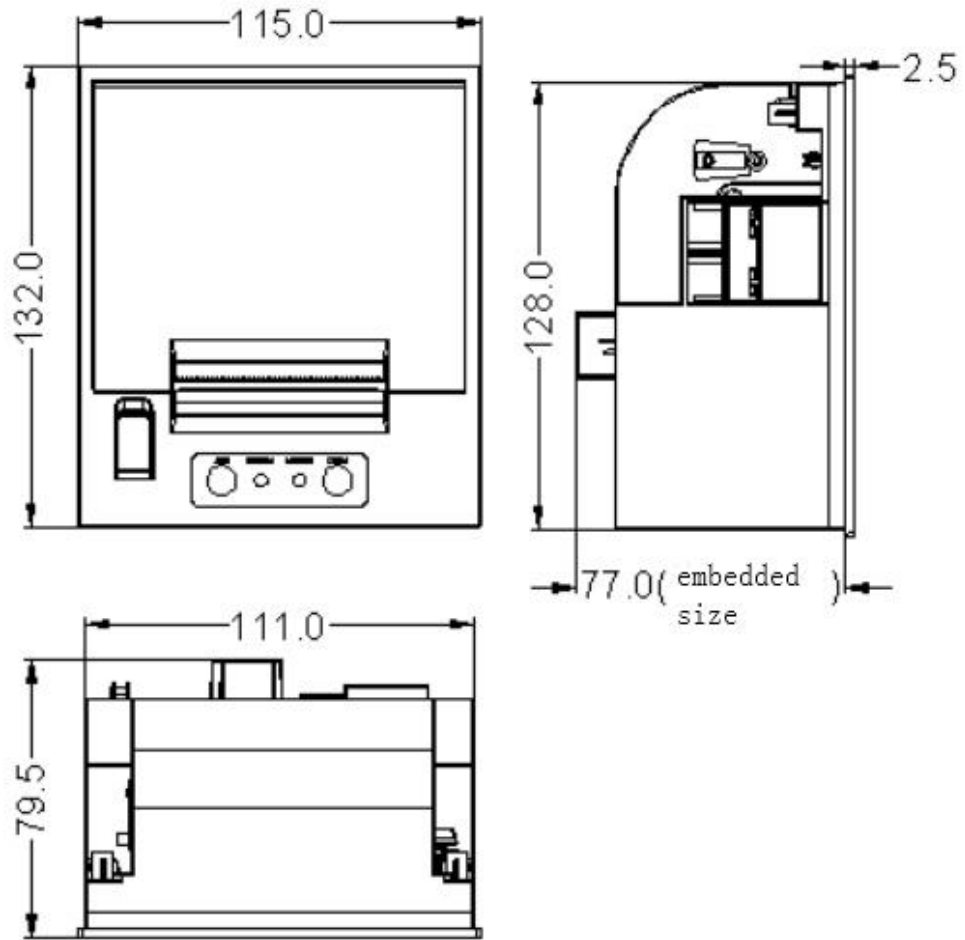

Pic.1-1 RMD17outline dimension drawing

## Chapter 2 Operation Specification

### 2.1 Printer Appearance

About the name of each part of printer, please refer to picture 2-1:

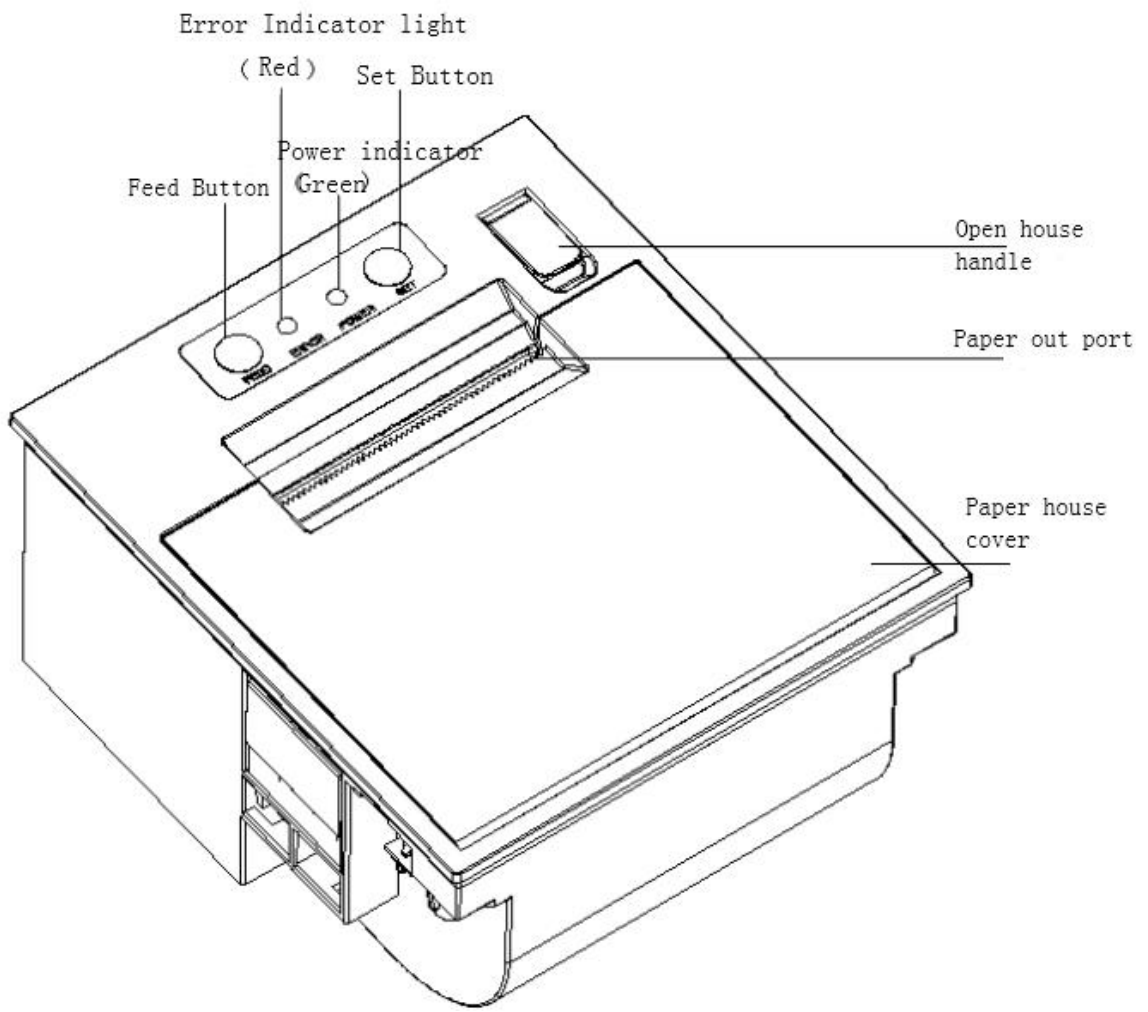

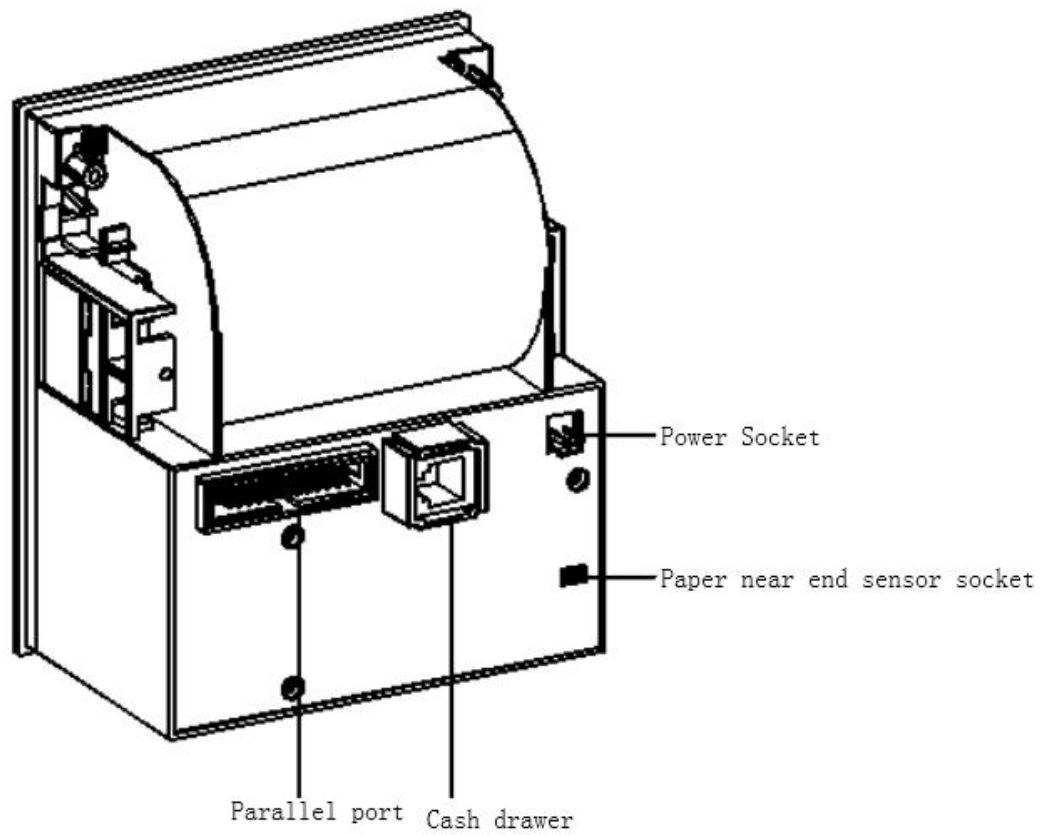
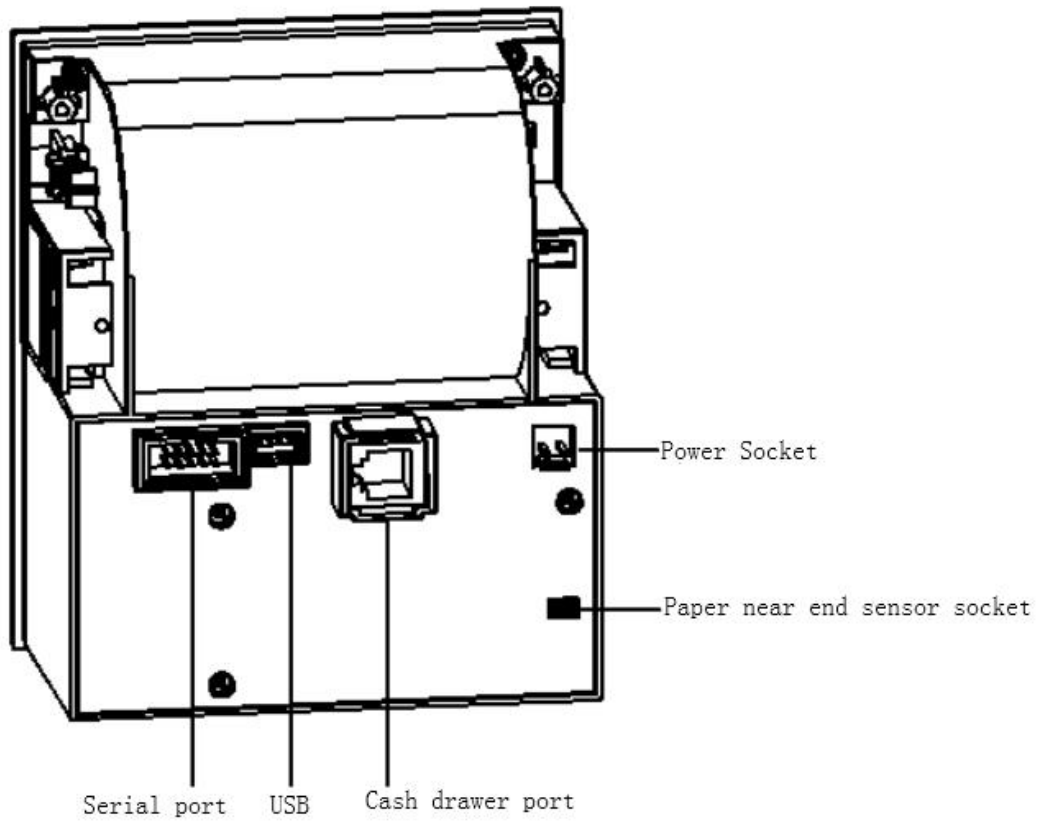

Fig.2-1 Printer Appearance

## 2.2 Installation of the printer

Embedded printer in the installing hole of customer's panel. open the printer paper cover, clockwise to tighten the two screws to complete the installation of the printer . Print installation shown in Figure 2-2.

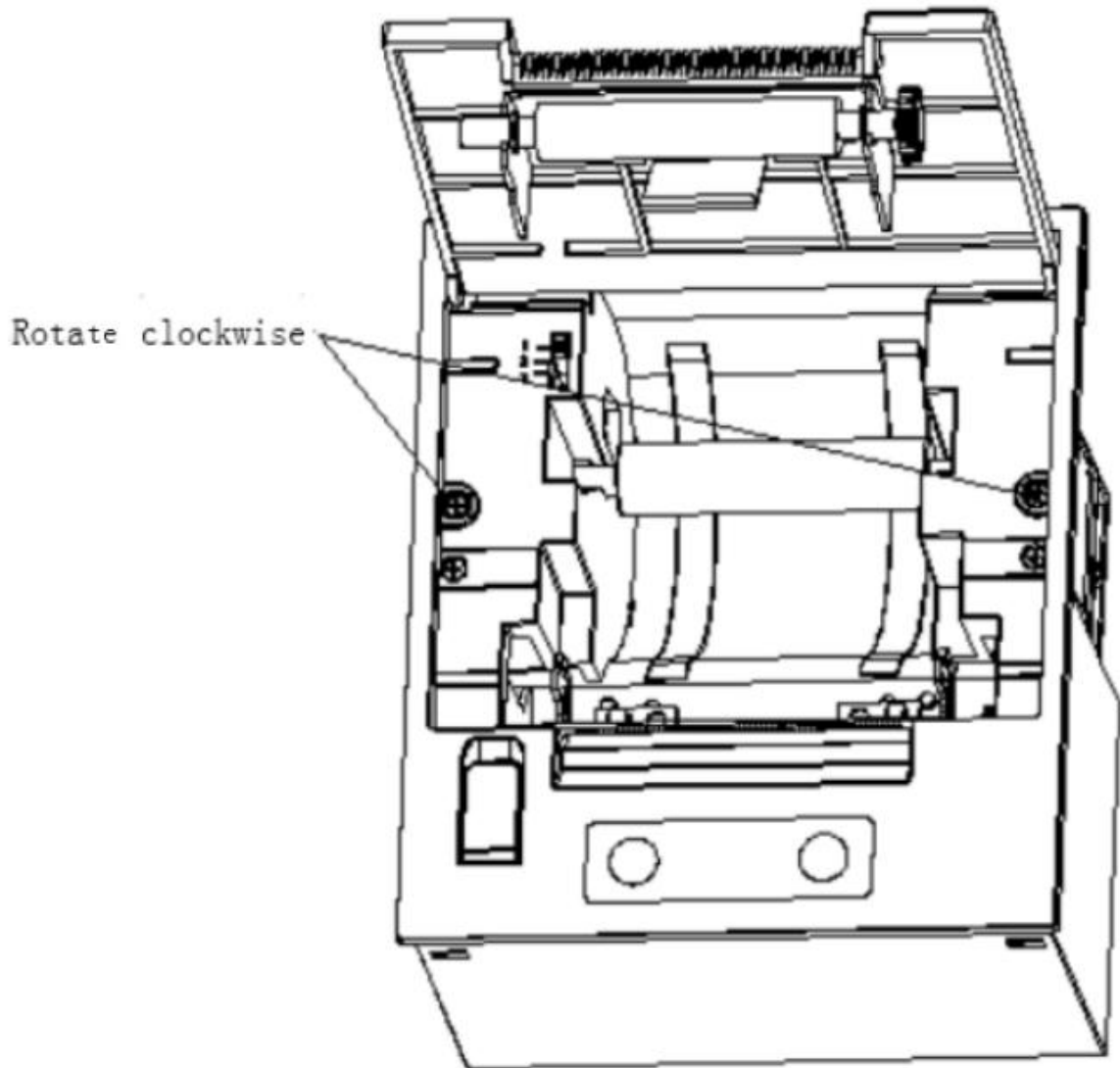

Fig.2-2 Printer installation pic.

## 2.3 Paper Installation

### 2.3.1 Paper Loading

RMD17 adopts 57.5mm±0.5mm width thermal paper roll.

Steps of Loading Thermal Paper are as below:

Hold down the upper cover button on the left side, open the movable upper cover, draw a certain length of the paper roll, put the paper end on the print head, close the upper cover and press it



downwards lightly.



**Caution!**

1. Pay attention to the direction of loading paper, make the printing surface face to the print head.
2. Please don't feed or draw the paper forwards or backwards with hands.
3. Keep clean of the print head, avoid to influence the printing quality.

## 2.4 Interface

### 2.4.1 Serial Interface

The serial interface of SP-RMD17 printer is compatible with RS-232C, supports DTR/DSR and XON/XOFF handshaking protocols, uses IDC10 socket. The pin order of the serial port is as Fig.2-3 shows:

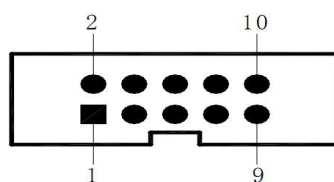

Fig.2-3 Pin Order of Serial Port

The pin assignment of serial interface is shown in Fig. 2-4:

Pin No.	Signal Name	Signal Direction	Source	Description
2	DTR	Output	Printer	Signal "MARK" means the host is busy and can not receive data. Signal "SPACE" means the host is ready to receive data.
3	TXD	Output	Printer	Printer transmits control code X-ON/X-OFF and data to host
4	DSR	Input	Host	Signal "MARK" means the host is busy and can not receive data. Signal "SPACE" means the host is ready to receive data.
5	RXD	Input	Host	Printer receives data from host

6	RTS	Output	Printer	Same with Pin No.2 DTR Signal
9	GND	-----	-----	Signal Ground

Fig. 2-4 The pin assignment of serial interface

Note: (1) "Source" denotes the source that signal come from;  
(2) Logical signal level is EIA.

The baud rate and data structure in serial interface mode is 9600bps, 8-bit data bits, no parity bit and 1 stop bit. The serial interface of SP-RMD17 can be connected to standard RS-232C interface. When it is connected to IBM PC or its compatible machine, connection can accord to Fig.2-5.

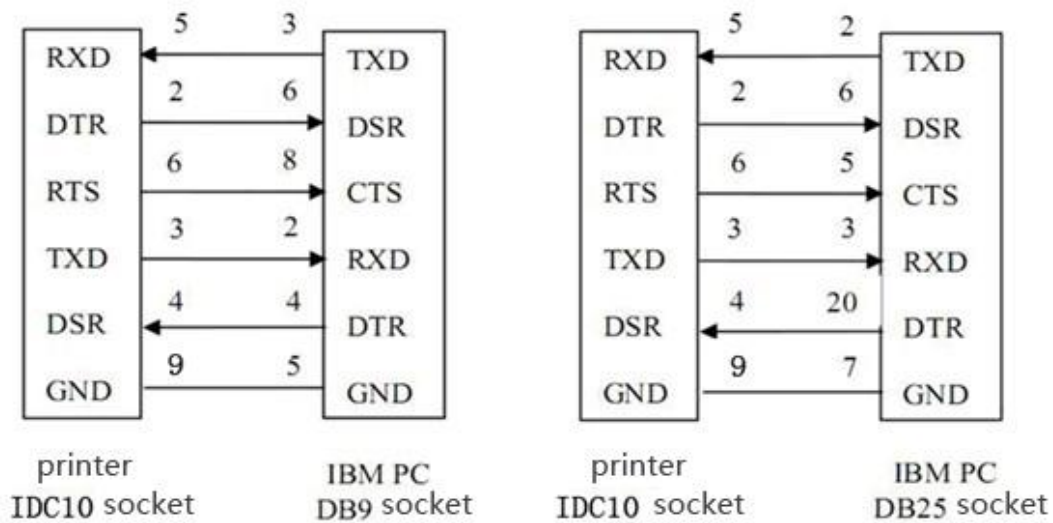
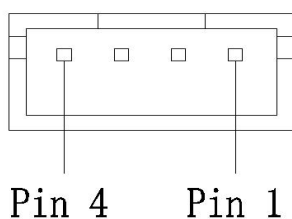

Fig.2-5 Connection between SP-RMD17 and PC Serial Interface

## 2.4.2 USB interface

The USB interface of the RMD17 printer is PH-4A interface, outer appearance and pin assignment is shown in Figure 2-6:



PIN Assignment	Function	Reference
1	V BUS	Power + 5V
2	Data-	Data -
3	Data+	Data +
4	GND	Ground

Figure 2-6: USB socket and pin definitions

### 2.4.3 Power Connection

SP-RMD17 printer uses the external power supply adopter as 12V±10%,2A, power socket is 2114S-02 model, as Fig. 2-7 shows:

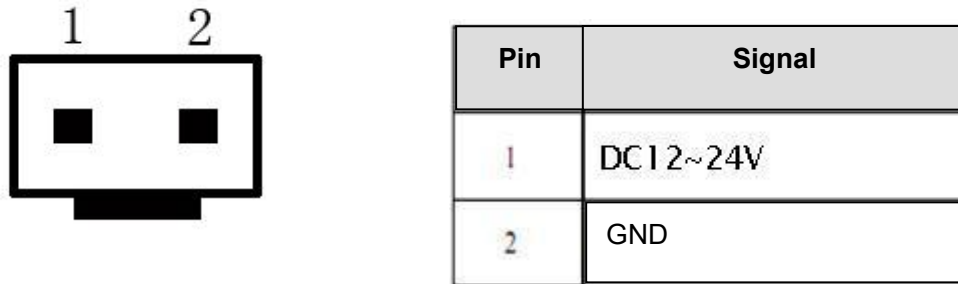
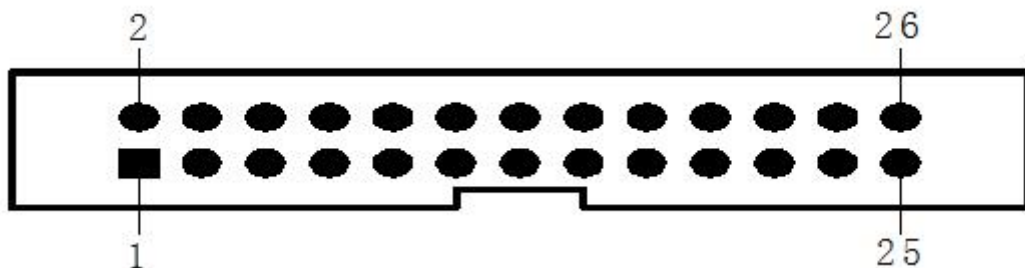

Fig.2-7: Power socket and pin assignment

### 2.4.4 Parallel interface connection

The parallel interface of RMD17 is compatible with CENIRONICS standard, and the interface socket is 36-pin flat cable socket, or its substitute for connecting with it. The pin order of parallel port is shown as below:



Pin No.	Signal	Direction	Explanation
1	/STB	in	Strobe pulse to latch data reading occurs at rising edge.
3	DATA1	In	These signals represent the 1st bit 8th bit of the parallel data respectively, each signal is at HIGH level when data is logic 1, and LOW when data is logic 0
5	DATA2	In	
7	DATA3	In	
9	DATA4	In	
11	DATA5	In	
13	DATA6	In	
15	DATA7	In	
17	DATA8	In	
19	/ACK	Out	Answering pulse, LOW level signal indicated that data have already been received and the printer gets ready to receive the next data
21	BUSY	Out	HIGH level signal indicates that the printer is

			BUSY and can not receive data .
23	/PE	Out	HIGH means printer is out of paper ; LOW means there is paper .
25	SEL	---	It is raised to "HIGH" level through electric resistance and means the printer is ONLINE .
4	/ERR	Out	HIGH means trouble free
2,6,8	NC	---	Unconnected
10,12,14,16,18,20,22,24	GND	---	Ground-connected .The logic is "0" level .

Notice: ① "in" means sending into the printer. Out means sending out from printer.

② The logic electrical level if signal is TTL electrical level .

## 2.4.5 Bluetooth Connection

Hand-held device, laptop and other information terminal devices with Bluetooth can drive SP-RMD17 to print by the Bluetooth interface. SP-RMD17 printer is compatible with Bluetooth2.0 standard. Power class is CLASS 2, effective communication distance is 10meters. The Bluetooth of the printer belongs to the slave device. The initial name of the printer is D17 BT Printer, the initial password is '1234'; users can change the printer name and password by using<SP-RMD17 Setting Tools> software. Please see the details in help file of <SP-RMD17 Setting Tools>.

Before working, SP-RMD17 Printer needs to be paired with primary device. Pairing begins from the host device. Usual pairing course is as below:

1. Power on printer;
2. Host device searches for the outer Bluetooth device;
3. If there are other Bluetooth devices, please select D17 BT Printer;
4. Enter the password '1234';
5. Pairing finished.

Please see details in primary device Bluetooth function instruction for reference.

### Illustration:

The Bluetooth of SP-RMD17 Printer divided into dual mode Bluetooth and one-to-many Bluetooth. Dual mode Bluetooth can support Android device and IOS 4.0, but only one device can be connected meanwhile. One-to-many Bluetooth supports seven Android devices and one IOS device connect printer simultaneously.

Notice:

1. When pairing, please keep SP-RMD17 printer switch on.
2. If the name of printer didn't changed, don't switch on more than one printer, otherwise it may confused which one paired successfully.
3. If Bluetooth connected successfully, green power indicators flickers every 500ms, and it will

keep green when Bluetooth disconnected.

## 2.4.6 Cash Drawer Interface

The cash drawer interface of RMD17 printer is RJ-11, 6 pin socket, as below:

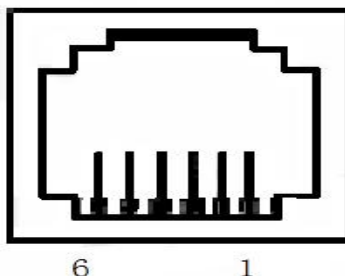

Pic.2-8, cash drawer port

The pin assignment of the cash drawer interface is as follows:

Pin No.	Signal	Direction
1	Chassis Ground	—
2	Cash drawer driver	Out
3	NC	—
4	+12VDC	—
5	NC	—
6	Signal ground	—

## 2.5 Indicators, Buzzer and Buttons Operation

There are two buttons, one inner buzzer and two indicators for RMD17.

Note: The specification of buffer is for the printers with buffer function.

【SET】 is setting button, the function of this button is on/off can be set by print command.

【FEED】 is paper feed button, the function of this button is on/off can be set by print command. When the function of this button on, press 【FEED】 button to feed paper; release 【FEED】 button to stop feeding button.

The buzzer can indicate the error and cutter status. Through parameters setting, the buzzer can be set into error alarm, paper-cut indicating or both above. The types of error status are same as ERROR indicator.

The green POWER light is the power indicator. POWER indicator lighting means the printer

is power on.

The red ERROR light is error status indicator. It is off when the printer works normally; while it flashes or persistently lights when the printer has abnormal alarm.







If ERROR indicator flashes or persistent lights and the buzzer sounds, it means the printer has error.

According to different flashing types, the different errors of printer are indicated:

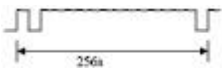
1. Unrecoverable error: the times of indicator flashing and buzzer sound indicate the error type, then indicator persistently light.
2. Recoverable error: the times of indicator flashing and buzzer sound indicate the error type, then indicator is persistently off.
3. Automatically recoverable error: the indicator flashes and the buzzer sounds continuously.
4. Paper out: the indicator light blinks, and the buzzer sounds persistently.

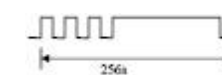
The details are as below:

- ①Unrecoverable error, the indicator flashes several times, then persistently lights. Then cycle. The times of flashing means the error type.

Error type	Description	Types of ERROR flashing
Unrecoverable error	LED flashes once : Memory read - write errors	
	LED flashes twice: Over-voltage	
	LED flashes three times: the voltage is lack	
	LED flashes four times: CPU Execution error (wrong address )	
	LED flashes five times : UIB error	
	LED flashes eight times : temperature detection of circuit is wrong	

- ②Automatically recoverable error: the indicator flashes continuously. Including printer head temperature error and house cover error.

Error type	Description	Type of flash
Automatically recoverable error	LED continues flashing : the temperature of printing head is over high and the cover is wrong	

## 2.6 Power on the printer

When the printer is off and paper case cover is closed, press the POWER button to turn on

the printer and the ERROR indicator flashes twice, then indicator off. The printer enters into the normal working mode.

## 2.7 Self test

The self-test will check the condition of printer, if the printer prints out the self-test receipt correctly, it means the printer works normally except interface with host. Otherwise it needs to repair.

Self test method: Under power off status, paper house closed and ensure there is paper inside, keep pressing FEED button and power on the printer, red indicator will flicker every 1s, then release FEED button after indicator flickers 3 times, printer will print out self-test paper. Self test paper can test the printer working normally or not, if the printer can print out self test normally, it means the printer is normal except interface with host, otherwise it need to be repair.

## 2.8 Hexadecimal Printing

Turn on the printer according to the step below, it will enter the mode of Hexadecimal Printing. Power off, Press **【FEED】** button with opening the paper house cover. Power on, close the paper house cover. The printer will print out 3 lines as below:

Hexadecimal Dump

To terminate hexadecimal dump,

Press FEED button three times.

This means the printer has entered hexadecimal printing mode, and under this mode, all of the input will be printed out as hexadecimal number. Paper will feed one line with single-click of "FEED" button, after 3 times, it will print out "\*\*\*\* Completed \*\*\*\*", and exit hexadecimal printing mode.

## 2.9 Printer Parameter Setting

This function is for the setup of parameters.

Steps for setting parameters:

Power off, press **【SET】** button and power on, the printer will enter into setting mode, and print the first parameter option and current setup. Details could be checked on attached Appendix A.

Steps for exiting of parameter setup:

Press **【SET】** button and **【FEED】** button at the same time to save the setup of parameter and exit, the printer will enter into normal mode. If power off directly, parameters will not be saved.

## 2.10 Entering program upgrading mode

When printer powers off, press **【FEED】** and **【SET】** buttons, power on and release the buttons. Printer will enter into upgrading mode, status indicator light will flicker every one second.

Notice: RMD17 only support USB interface and parallel interface can support program upgrading online.

## Appendix A: Parameter Setting

This appendix is the method of setting default parameters of printer by buttons.

Setting instruction: Using **【SET】** button to choose setting item. Pressing this button once, the setting item will go to the next and also print out the current value of this item. Using **【FEED】** button to choose the setting value of item. Press the button once, the setting value will go to the next.

Summary Setting:

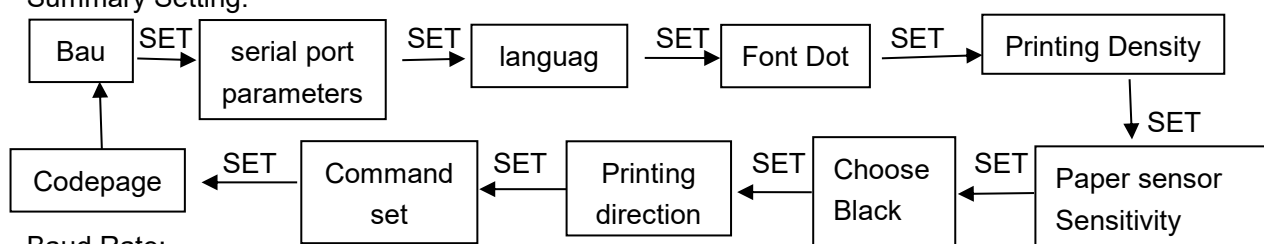

Baud Rate:

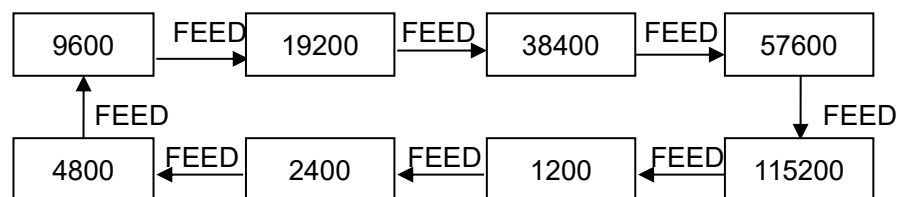

Serial port parameters:

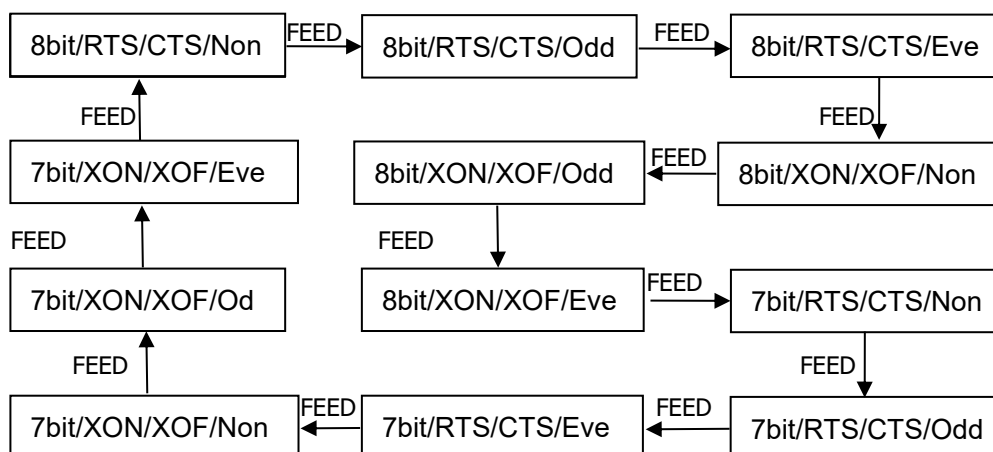

Language:





Font size:

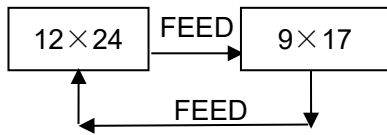

Printing density:

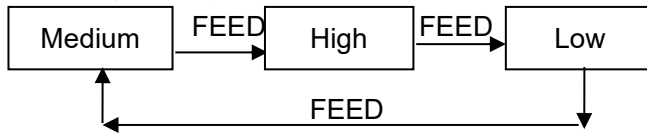

Paper sensor sensitivity:

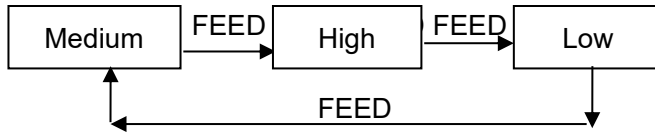

Choose black mark:

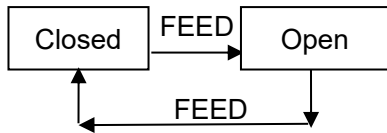

Printing direction:

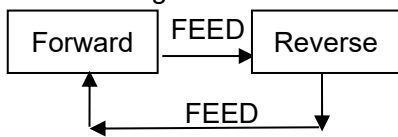

Command set:

