

SPRT®
®

SP-RMT9 BT

Portable Thermal Printer

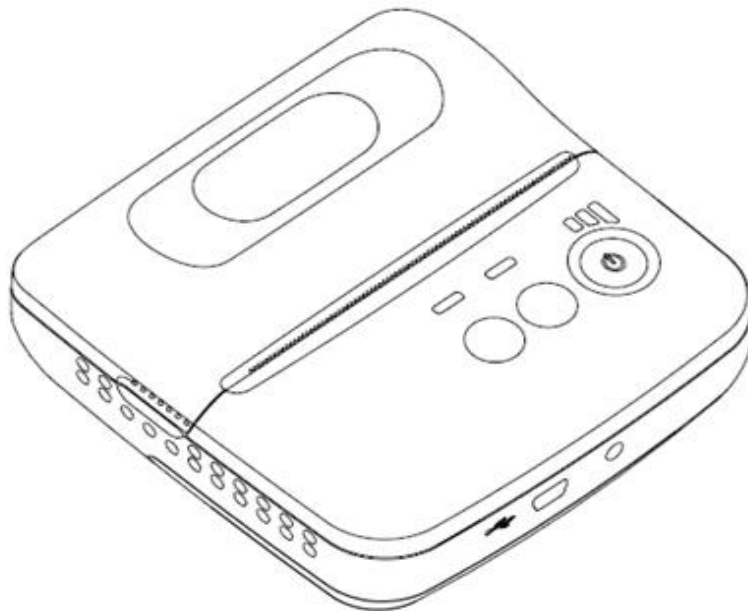

User's Manual

(Ver1.05)

Beijing Spirit Technology Development Co., Ltd

www.spirt-printer.com

Content

NOTICE.....	1
Declaration.....	4
Chapter 1 Outer Appearance and Model No.....	4
1.1 Outer Appearance.....	4
1.2 Model No.....	4
Chapter 2 Characteristic Specification.....	5
2.1 Printing Specification.....	5
2.2 Physical Parameters.....	5
2.3 Environment.....	5
2.4 other Specification.....	6
Chapter 3 Operation Method.....	6
3.1 Using Preparation.....	6
3.1.1 Battery Installation.....	6
1. Put the battery into the battery slot.....	6
2. Install the battery cover.....	6
3.1.2 Paper Roll Installation.....	7
3.1.3 Others.....	7
3.2 Basic function usage.....	8
3.2.1 Switch On.....	8
3.2.2 Switch Off.....	8
3.2.3 Paper Feeding (Manual Feeding).....	8
3.2.4 Self-Test.....	8
3.2.5 Hexadecimal Printing.....	8
3.2.6 Printer Parameters Setting.....	9
3.2.7 Battery Charging.....	9
3.3 Printer Parameters Setting.....	9
3.4 Printer Interface Connection and Printing.....	10
3.4.1 USB Connection.....	10
3.4.2 Bluetooth Connection.....	10
3.4.3 Function of Bluetooth Address Binding.....	11
3.5 Indicator and Buzzer.....	11
Chapter 4 Other Information.....	13
APPENDIX A.....	14

NOTICE

Please read this manual carefully before using the printer!

Notice of Safety

Be sure to use the specified battery and power supply provided by our company. Otherwise it may cause fire, explosion or damage printer, meanwhile, the battery also may be damaged.

Don't put battery into the fire, don't disassemble or heat the battery, don't be short circuit, it may cause fire, explosion or damage printer, meanwhile, the battery also may be damaged.

If the printer would not be used for a long time, be sure to take off the battery, otherwise the battery may leak liquid which is corrosive liquid, if improper operation causes battery leak liquid, and it paste in the skin or clothes, please rinse it by clean water, if paste in the eyes, please rinse them thoroughly by clean water and see a doctor. Please do not open the paper case cover when it is printing or just when printing is finished, do not touch the printer head with hand or body, overheat may cause scald.

Notice of Using

Water or other liquid should not be spilled into the printer, also the printer should not be appeared in the rain, or else may cause printer damage. Please do not open the paper case cover when it is printing, otherwise the printer may work improperly. If printer is using USB connection to work, should not unplug the USB cable, or else some printing data may be lost. When printer is using USB connection to work, the distance of communication should be within 10 meters, otherwise the printer doesn't print or prints rubbish codes. Too high (45°C) or too low (5°C) environment temperature and too high (85%) or too low (20%) environment humidity both effect the printing quality. The printer paper roll with poor quality or stored for too long time also may reduce the printing quality even damage the printer. Under the black mark detecting mode, the printer requires that the pre-printed black mark is accordant with the printing rule of black mark (please refer to details in Chapter 4.2), otherwise the black mark can not be detected correctly. Be sure to use up the power of the battery before charge up it, as it can ensure the using life of the battery.

Notice of Storing

The printer should be placed in such an environment that the temperature is between -20°C and 60°C , and the relative humidity is between 10% and 90%. If the printer will be stored for a long time, please be sure to take out the battery, otherwise may damage the battery and printer.

Normal thermal paper receipt can't be kept too long, if you need to keep the receipt for a long period, please choose long-term effective thermal paper. The thermal paper should be keep away from high temperature environment and point-blank sunshine, please store it where is away from light if it have been open.

Declaration

This product is "A" grade. In a domestic environment this product may cause radio interference in which case the user may need to perform practical actions.

Chapter 1 Outer Appearance and Model No.

1.1 Outer Appearance

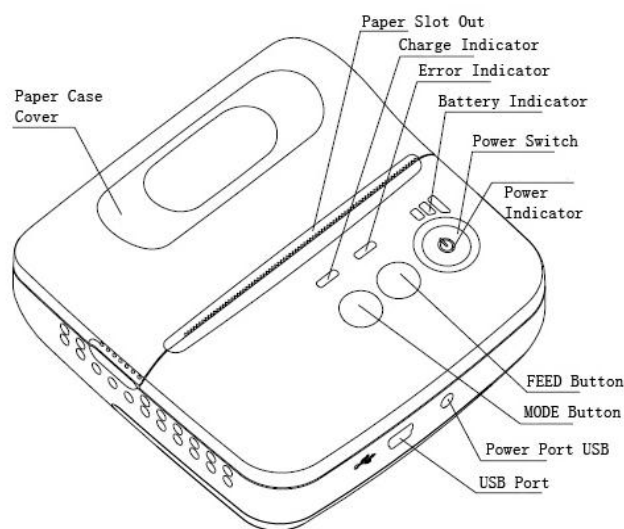

[CHARGE]: Battery Charging Indicator Indicator

[ERROR]: Error

[FEED]: Feed Button

[MODE]: Mode Button

1.2 Model No.

SP—RMT9

Support USB Interface

Chapter 2 Characteristic Specification

2.1 Printing Specification

Printer Method: Thermal line

Paper Width: 79.5± 0.5mm

Effective Printing width:72mm

Resolution: 8 dots/mm (203dpi)

Dots in each line: 576dots/line

Printing Speed: 80mm/s (Max)

Paper Thickness: 0.06-0.08mm

Printable Content:GB18030(Chinese) BIG5(traditional Chinese),ASCII characters, self-defining character.

Barcode:

1D:UPCA,UPCE,EAN13,EAN8,CODE39,ITF25,CODABAR,CODE 93,CODE 128

2D: PDF417,QR CODE,DATA Matrix

2.2 Physical Parameters

Dimension (W×L×H): 105(L) X101(W) X46(H) mm

Physical Weight: 254g (excluding roll paper)

Paper Type: thermal paper 79.5mm x40mm (MAX)

Interface: USB, Bluetooth

Printing Head Life: 50km

2.3 Environment

Operating Temp: 0°C~50°C

Operating Humidity: 10%~80% (relative humidity)

Storage Temp: -20°C~60°C

Storage Humidity: 10%~90% (relative storage humidity)

2.4 other Specification

- Paper Loading Method: drop-in easy loading (please refer to details in 3.1.2 Paper Roll Installation).
- Paper Tearing Method: Manually tearing
- Black Mark Location: available(details please see 4.2 pre-printed black mark manual).
- Paper End Sensor: when paper is out, the ERROR Indicator will constant on lighting, The buzzer rings when it is printing, and it will stop printing.
- Printing Control Command: ESC/POS compatible command set.

(refer to<T9 Printer Developer Manual >)

- Power Supply: 7.4V/1500mAh rechargeable polymer lithium battery.
- Low Power Alarm: When the electric of battery will run out, the power indicator will be red to alarm.
- Battery Charging: quick charging ,it will be charged full about 3 hours;
- Battery Duration: under25% printing density ,at least 120 meters, the standby time is over 100 hours. (These parameters are just for reference, long term usage will cause the capacity decline, and can not ensure the time of printing.)

Chapter 3 Operation Method

3.1 Using Preparation

3.1.1 Battery Installation

1. Put the battery into the battery slot.
2. Install the battery cover.

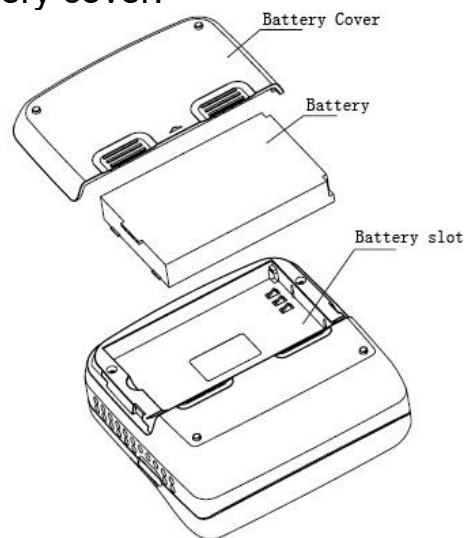

3.1.2 Paper Roll Installation

1. Hold both sides of the paper case cover, and open it.
2. Pay attention to use paper that effective printing side is outside in the printing paper face when you install the new paper roll.
3. Pull out a part of paper and put them in the middle of the paper out orifice.
4. Shut down paper case cover and cut off the redundant paper

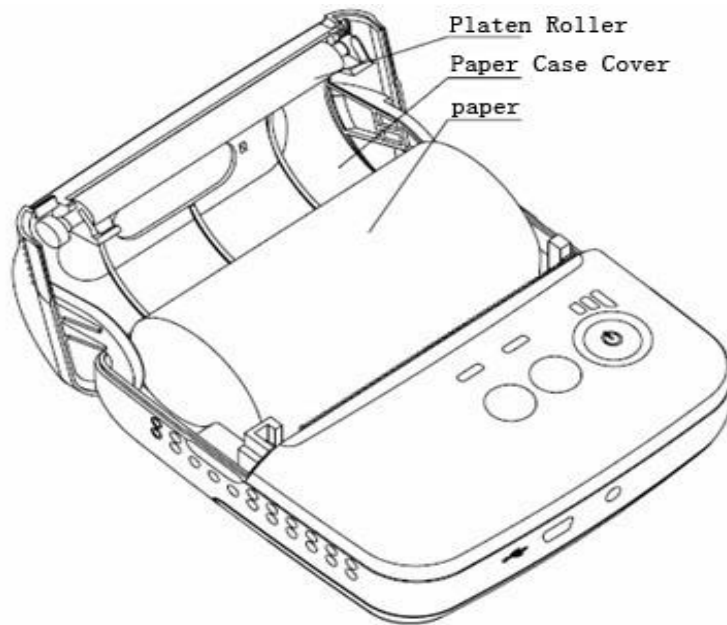

3.1.3 Others

Opening and closing the case instruction: Pls make sure the right and left side are open or close at the same time.

Abnormal operation instructions: The outlet is not allowed to be blocked

Place the direction: When printing, hold it horizontally to ensure the stability of the paper roll.

3.2 Basic function usage

3.2.1 Switch On

Press **【POWER】** button, the power indicator is on, about 1 second later you will hear 'one low one high' prompt tone. The printer will turn into work mode when loosen the **【POWER】** button. The battery indicator shows power of the battery.

3.2.2 Switch Off

Under status of switch on, the printer will send out the prompt tone of 'one low one high' after pressed the **【POWER】** button for 1 second, the power indicator go out, then loosen the **【POWER】** button, the printer is off.

3.2.3 Paper Feeding (Manual Feeding)

Under the normal work status, press **【FEED】** button, the paper feeding begins, and stop when loosen **【FEED】** button. When the printer works in black mark mode, press **【FEED】** button, the printer begins to feed paper and stops over the position of black mark. If the paper is not the black mark paper, the printer stops automatically after feeds paper for 30cm.

3.2.4 Self-Test

After receiving the printer, user can check its current setting and status at anytime.

Self-test way is as below: Power off, then hold down the **【FEED】** button and press the power button at the same time. Then loosen the **【FEED】** button and power button when you hear 'one low one high' prompt tone, the current setting and status will be printed out.

3.2.5 Hexadecimal Printing

The function of hexadecimal printing is to print the information received from host machine by hexadecimal numbers and corresponding characters. It will be convenient to debug application.

Into hexadecimal printing: Power off, hold down the **【MODE】** button and press the power button at the same time. Then loosen the power button and press the **【FEED】** button when you hear 'one low one high' prompt tone of power on. After that you may loosen the **【MODE】** button and **【FEED】** button. The printer turns into the hexadecimal printing mode and print the presentation.

Quit hexadecimal printing :The way to quit hexadecimal printing mode is switch off the printer or press the **【FEED】** button for three times. The printer will also print the presentation which shows that the printer have quitted hexadecimal printing mode.

3.2.6 Printer Parameters Setting

This function may set some simple printing parameters.

Entering parameter setting: Switch off, then hold down the **【MODE】** button and press the **【POWER】** button at the same time. Then loosen the **【POWER】** button and **【MODE】** button when you hear 'one low one high 'prompt tone. The printer turns into the parameters setting mode. Print out the first item which can be set parameters and the current numerical value. Please see details in the appendix as below.

Quitting parameter setting: Hold down **【MODE】** and **【FEED】** buttons, then loosen **【MODE】** button and **【FEED】** button. Saving the set parameter and exiting the parameter setting mode. The setting parameters won't be saved if you directly press the **【POWER】** button to turn off the printer.

3.2.7 Battery Charging

The battery will run out after a period of usage. When it nearly runs out, printer will give a alarm through the battery indicator flashing, at this time, user needs to charge up the battery.

The charging method is as following: connecting the adapter to the power socket with 220V, 50HZ, then plug the power charging plug to the power socket of the printer, so the power charging begins. During the course of power charging, the charging indicator 【CHARGE】 goes red, and 【CHARGE】 turns to blue when the charging is full. It takes about 3 hours to charge up the battery. Using the printer during the course of charging power will make the charging time go longer. It shows the failure if the charging indicator 【CHARGE】 goes blue and red during the course of charging. Such as faulty installation of battery, faulty contact of battery or internal temperature of battery is too high or too low.

3.3 Printer Parameters Setting

Users can set more parameters by using the specified 〈T9 Setting Tools〉 software through computer. The setting includes: language、font、printing density、default code page、bluetooth device name and password etc. The setting method please refer to the <T9Setting Tools Software Help>, offered with the software together.

3.4 Printer Interface Connection and Printing

3.4.1 USB Connection

The SP-RMT9 printer of standard accessories includes Mini USB cable which connects printer. The USB type belongs to the slave device type.

3.4.2 Bluetooth Connection

Handheld device, laptop and other information terminal devices with Bluetooth can drive SP-T9BTDM to print by the Bluetooth interface. SP-T9BTDM portable printer is compatible with Bluetooth2.0 & 4.0 standard. The effective communication distance is 10meters. The Bluetooth of the printer belongs to the slave device. The initial name of the printer is T9 BT Printer Printer, the initial password is '1234'; users can change the printer name and password by using <Setting Tools> software. Please see the details in help file of <Setting Tools> software.

Before working, SP-T9BTDM Portable Thermal Printer need to be pairing with primary device, matching begins with the host device. Usual matching course is as below:

1. Switch on printer;
2. Host device searches for the outer Bluetooth device;
3. If there are other Bluetooth devices, please select SP-RMT9 BT Printer;
4. Enter the password '1234';
5. Pairing finished.

Please see details in primary device Bluetooth function instruction for reference.

Notice:

1. When pairing, please make SP-RMT9 BT switched on.
2. Once the BT device is paired with the host successful, it can't be paired with other Bluetooth device until it unconnected with the host one.
3. The power indicator flashes after paired successful.

3.4.3 Function of Bluetooth Address Binding

Bluetooth Binding: once the printer remembers the device's address, it only can connect with the first device and can't connect with others. So in this case, if the printer needs to connect with other devices, user can delete the remembered address or set the mode is not binding.

No binding: in this case, the printer can be searched or paired by other devices. So when the printer needs to connect with a fixed device, it would be better to bind address. Please see the details in help file of<T9 Setting Tools>

3.5 Indicator and Buzzer

There are four indicators, they are red and blue **【CHARGE】** light, red**【ERROR】**light, blue **【BATTERY】**indicator and blue**【POWER】** indicator. The meanings of each indicators are as below:

【POWER】 indicator

Light constant on: printer is on, Bluetooth is with disconnect status

Light flashing: printer is on, Bluetooth is with connection status

【CHARGE】 indicator

Blue light constant on: charging is completed;

Red light constant on: in charging;

Blue and red lights on: there are some mistakes, please check whether the battery should be good contact or not, and the temperature is normal or not.

【ERROR】 indicator

Constant on lighting: printer out of paper





Light flashing: printer has mistakes. Different types of mistake, different ways of flashing

1. The mistake can be automatically recovered when the indicator continuous flashing. Including the temperature mistake of printer head and opening of paper case cover.

Error	Description	The flashing way of 【ERROR】 ERROR
Temperature of printer head	The temperature of printer head is too high, it will recover automatically when the temperature is normal	

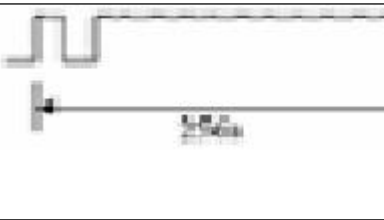
Paper case cover of printer	The paper case cover is opened when it is printing. Close the paper case cover, it will recover automatically	
-----------------------------	---	--

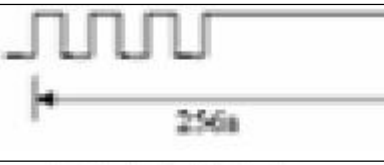
2. The mistake can't be automatically recovered when the indicator flashing some times and constant on then cycle. The times of flashing means the type of mistake.

Error	Description	The flashing way of [ERROR] ERROR
Memory ERROR	The printer can't work normally after the memory need to be read-write calibration	
Over voltage	The voltage of power is too high	
Owe voltage	The voltage of power is too low	
The CPU execution	The CPU execution to the wrong address	
Temperature detection circuit	Connection of temperature detection circuit connection error	

【BATTERY】 indicator

The battery indicator composed by three parts in order to show the battery status.

Three parts light on: battery is high

Two parts light on: battery is medium

One part light on: battery is low

Minimum part flashing: battery is extremely low, it must be charged

Three parts flashing at same time: power supply should be over voltage (external power supply without battery)
There is also a buzzer to indicate various status of the printer. The meanings are as below:
One low one high: power on;
One high one low: power off;
Circulation continuous two lows: printer at mistakes status

Chapter 4 Other Information

4.1 Command Programming Manual

<T9 Technical Manual> is a technical manual for engineer to develop printer utility, and users can claim our company for it. This manual including the technical description of hardware interface (Bluetooth, USB interface), technical documentation of printing control command set, and others such as how to print black mark and locate by it.

4.2 Description of Black Mark Pre-print

If user use pre-print black mark to locate the receipt, please be sure to abide by the following black mark pre-print regulation when print the black mark paper, if not ,it will cause that the printer can not identify the black mark.

The black mark pre-print regulations are as below:

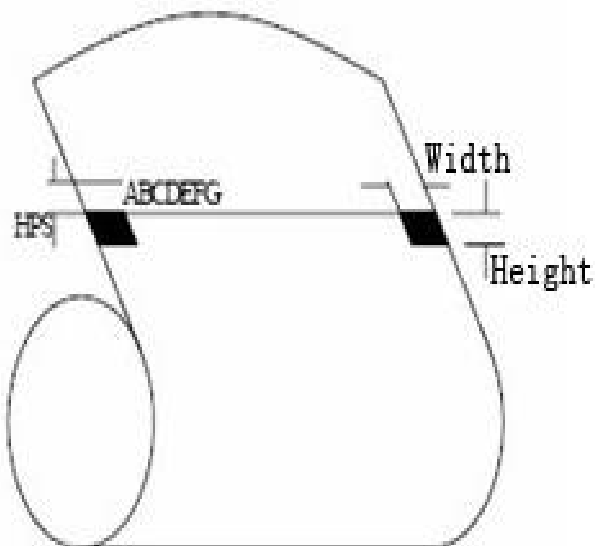

Printing Position: As the picture above, the black mark should be printed on the right or left edge of the side of words.

Width range: width \geq 7mm

Height range: $4\text{mm} \leq \text{height} \leq 6\text{mm}$

Reflectivity of infrared ray : $<10\%$ (infrared ray reflectivity of other parts of the black mark paper is $>65\%$)

HPS: it is the distance between edges of black mark and loading position.

$4.5\text{mm} \leq \text{Hps} \leq 6.5\text{mm}$

APPENDIX A

This appendix is the method of setting default parameters of printer by buttons.

Setting instruction: Using **【MODE】** button to choose setting item. Pressing this button once, the setting item will go to the next and also print out the current value of this item. Using **【FEED】** button to choose the setting value of item. Press the button once, the setting value will go to the next.

Summary setting:

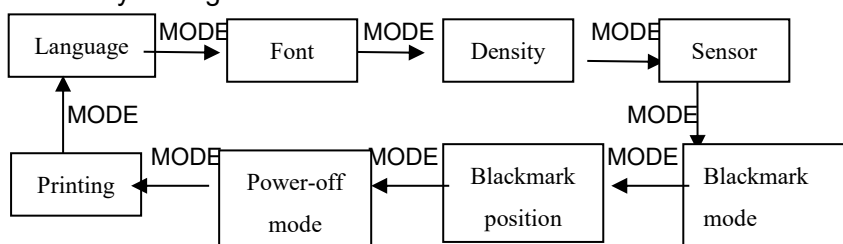

Language:

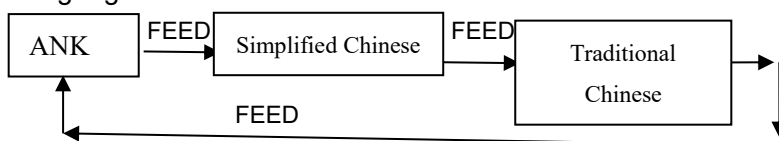

Font:

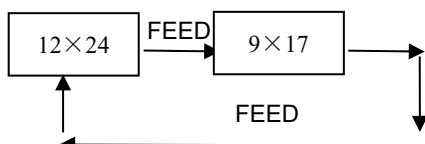

Density:

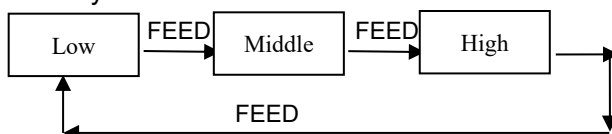

Sensor sensibility:

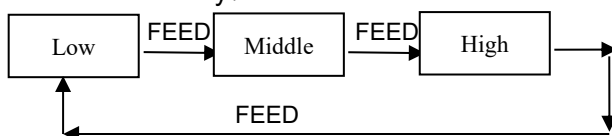

Blackmark mode:

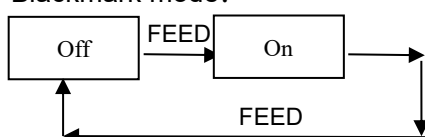

Blackmark position:

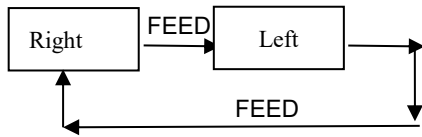

Power-off mode:

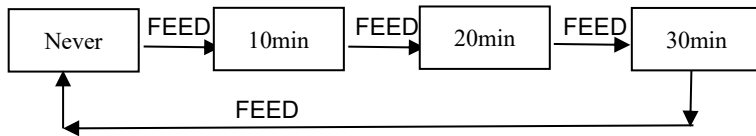

Printing direction:

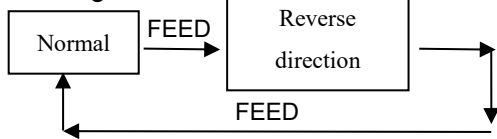

Warning

This is a class A product. In the domestic environment, this product may cause radio interference, in which case the user may be required to take adaptable measures.

Manufacture has right to amend the content of the instruction without prior announcement!